

KE-436B

パーツブック
PARTS BOOK



本縫電子模様縫ミシン 間欠押え・プログラム作成機能付

ELECTRONIC LOCKSTITCH PATTERN TACKER WITH STEPPING FOOT
AND PROGRAMMING FUNCTION

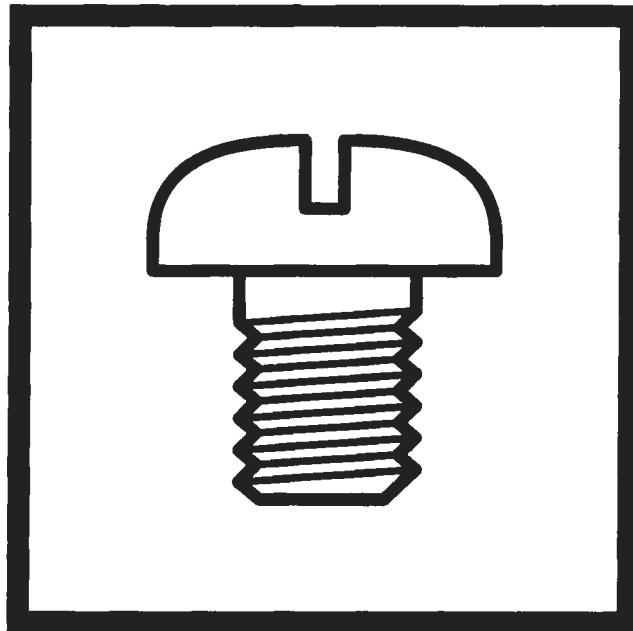

brother[®]

From the library of: Superior Sewing Machine & Supply LLC

パーツブックご利用に際して

1. この本は、2001年8月のデータに基づいて作成されたものです。
2. 部品は予告なしに設計変更される場合があります。
3. 組単位で補給する部品は、[]破線で示しております。
4. 部品コード欄が※となっている場合は、仕様別部品一覧表、ゲージ部品一覧表(59~62ページ)でお調べ下さい。

目 次

A. 主体関係	1	P. プリント基板関係	33
B1. 上軸・針棒関係	3	Q1. コントロールボックス関係	35
B2. 上軸・針棒関係	5	Q2. コントロールボックス関係	39
C1. 送り関係	7	R. 空圧関係	43
C2. 送り関係	11	S. 電装品関係	45
C3. 送り関係	13	T. 操作パネル関係	47
D. 押エ上げ関係	15	U1. 踏板関係	49
E. 下軸関係	17	U2. 踏板関係(オプション部品)	51
F. 給油潤滑関係	19	V. 動力台関係	53
G. 糸通シ関係	21	W. プログラマー関係 (オプション部品)	53
H. 糸巻関係	23	Z. 付属品関係	55
J. 糸切り関係	25	Sp. 仕様別部品一覧表	59
K. 糸払い関係	29	Ga. ゲージ部品一覧表	61
L. 糸取り関係	29	Wa. 警告ラベル	63
M. 糸締め関係	31	索引	64
N. 針位置検出器関係	33		

Notes for using this parts book

1. This book was prepared based on information available in August 2001.
2. Parts are subject to changes in design without prior notice.
3. Parts supplied as complete assemblies are circled by a dotted line [] .
4. If the symbol ※ is found in the "Parts No." column, refer to the Different parts list, gauge parts list on page 59~62.

CONTENTS

A. Machine body	1	P. Printed circuit board mechanism	33
B1. Upper shaft and needle bar mechanism	3	Q1. Control box mechanism	35
B2. Upper shaft and needle bar mechanism	5	Q2. Control box mechanism	39
C1. Feed mechanism	7	R. Air pressure mechanism	43
C2. Feed mechanism	11	S. Power supply equipment mechanism	45
C3. Feed mechanism	13	T. Operation panel mechanism ...	47
D. Work clamp lifter mechanism ...	15	U1. Foot switch pedal mechanism ..	49
E. Lower shaft mechanism	17	U2. Foot switch pedal mechanism (Option parts)	51
F. Lubrication	19	V. Power table	53
G. Threading mechanism	21	W. Programmer (Option parts)	53
H. Bobbin winder mechanism	23	Z. Accessories	55
J. Thread trimmer mechanism	25	Sp. DIFFERENT PARTS LIST	59
K. Thread wiper mechanism	29	Ga. Gauge parts List	61
L. Thread take-up mechanism	29	Wa. Warning labels	63
M. Thread nipper mechanism	31	Index	64
N. Synchronizer	33		

A . 主体関係 / Machine body

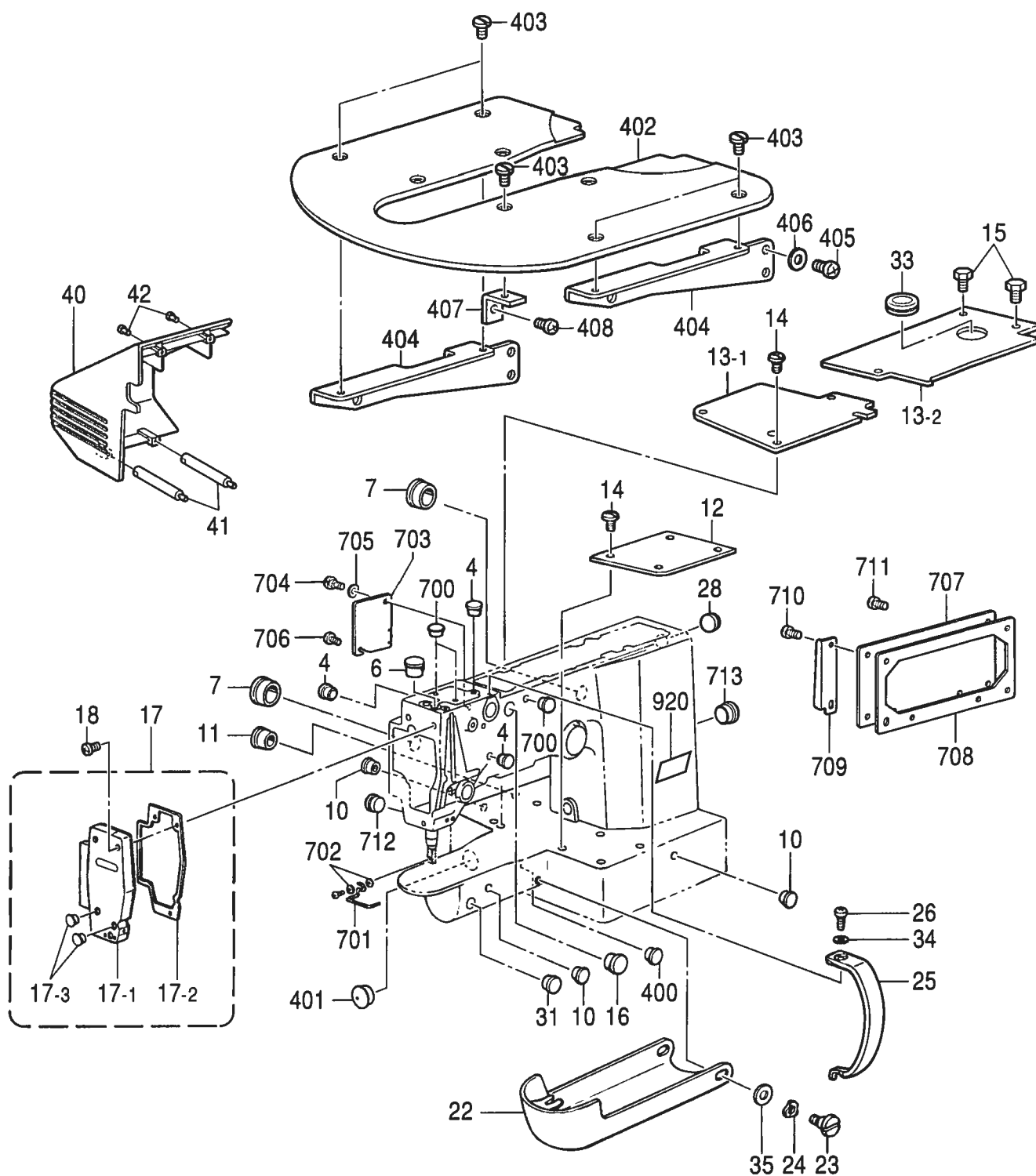

A. 主体関係 / Machine body

REF.NO.	CODE	Q'TY	ヒンメイ	NAME OF PARTS	RM
4	104450101	3	ゴムセン8	RUBBER CAP, 8	
6	117934001	1	ゴムセン13.5	RUBBER CAP, 13.5	
7	140392009	2	オイルフタ	OIL CAP	
10	104450101	3	ゴムセン8	RUBBER CAP, 8	
11	104449001	1	ゴムセン15.5	RUBBER CAP, 15.5	
12	S37915009	1	ヘッドカバーR	BED COVER, R	
13-1	S53119001	1	ヘッドカバーLF	BED COVER, LF	
13-2	S53120001	1	ヘッドカバーLR	BED COVER, LR	
14	106629002	9	シメネジ4.37	SCREW, SM4.37	
15	017680512	2	ボルト4.37X5	BOLT, SM4.37X5	
16	S23337001	1	ゴムセン18.5	RUBBER CAP, 18.5	
17	S42750209	1	メンイタクミ	FACE PLATE ASSY	
17-1	S42751109	1	メンイタ	FACE PLATE	
17-2	S42752000	1	メンイタハツキン	PACKING, ;F-PLATE	
17-3	117934001	2	ゴムセン13.5	RUBBER CAP, 13.5	
18	062711012	3	ナヘコ476-32X10	SCREW, PAN SM4.76-32X10	
22	152842059	1	オオカマカバークミ	SHUTTLE RACE COVER ASSY	
23	S57925001	2	ダンネシ6.35	SHOULDER SCREW, SM6.35	
24	109239002	2	ナミバネザガネ	WASHER, WAVE SPRING	
25	S55208000	1	テンビンカバー	COVER, ;T/TAKE-UP LEVER	
26	062681012	1	ナヘコ437-40X10	SCREW, PAN SM4.37-40X10	
28	S20164001	1	ゴムセン13	RUBBER CAP, 13	
31	S44010001	1	ゴムセン11.5	RUBBER CAP, 11.5	
33	S51460009	1	グロメツトMG-9	RUBBER CAP, MG-9	
34	100645003	1	ザガネ	WASHER	
35	025080132	2	ヒラザガネシヨウ8	WASHER, PLAIN S 8	
40	S51098000	1	ソクメンカバーIM	FRAME SIDE COVER, IM	
41	S53182101	2	ヘルトカバーシチュウ	STUD, BELT COVER	
42	062711012	4	ナヘコ476-32X10	SCREW, PAN SM4.76-32X10	
400	104450101	1	ゴムセン8	RUBBER CAP, 8	
401	140392009	1	オイルフタ	OIL CAP	
402	S51461001	1	ハリイタホシヨイタ	AUXILIARY PLATE, ;N-PLATE	
403	106629002	8	シメネジ4.37	SCREW, SM4.37	
404	S51459001	2	ホシヨイタササエ	SUPPORT, ;AUX .PLATE	
405	062761012	4	ナベコ595-28X10	SCREW, PAN SM5.95-28X10	
406	025060232	4	ヒラザガネチユウ6	WASHER, PLAIN M 6	
407	S10091201	4	ハリイタホジヨイタササエ	AUXILIARY PLATE SUPPORT	
408	060680712	4	バインド437-40X7	SCREW, BIND SM4.37-40X7	
700	117936001	3	ゴムセン9.4	RUBBER CAP, 9.4	
701	S02445001	1	フィンガーガード	FINGER GUARD	
702	025350236	2	ヒラザガネチユウ3.5	WASHER, PLAIN M 3.5	
703	S54145001	1	カンケツカバー	STEPPING COVER	
704	107321003	1	ダンネジ4.76	SHOULDER SCREW, SM4.76	
705	107017002	1	ナミバネザガネ	WASHER, WAVE SPRING 6.45	
706	060670612	1	バインド357-40X6	SCREW, BIND SM3.57-40X6	
707	S43907109	1	ソクメンカバー	FRAME SIDE COVER	
708	S41290201	1	OYSTリツケイタハツキン	OYS SET PLATE PACKING	
709	S41060109	1	メカクシイタ	BLIDE PLATE	
710	062710812	4	ナベコ476-32X8	SCREW, PAN SM4.76-32X8	
711	062710812	2	ナベコ476-32X8	SCREW, PAN SM4.76-32X8	
712	104449001	1	ゴムセン15.5	RUBBER CAP, 15.5	
713	104449001	1	ゴムセン15.5	RUBBER CAP, 15.5	
920	S44629001	1	Eマーク	LABEL, E	

B1 . 上軸・針棒関係 / Upper shaft and needle bar mechanism

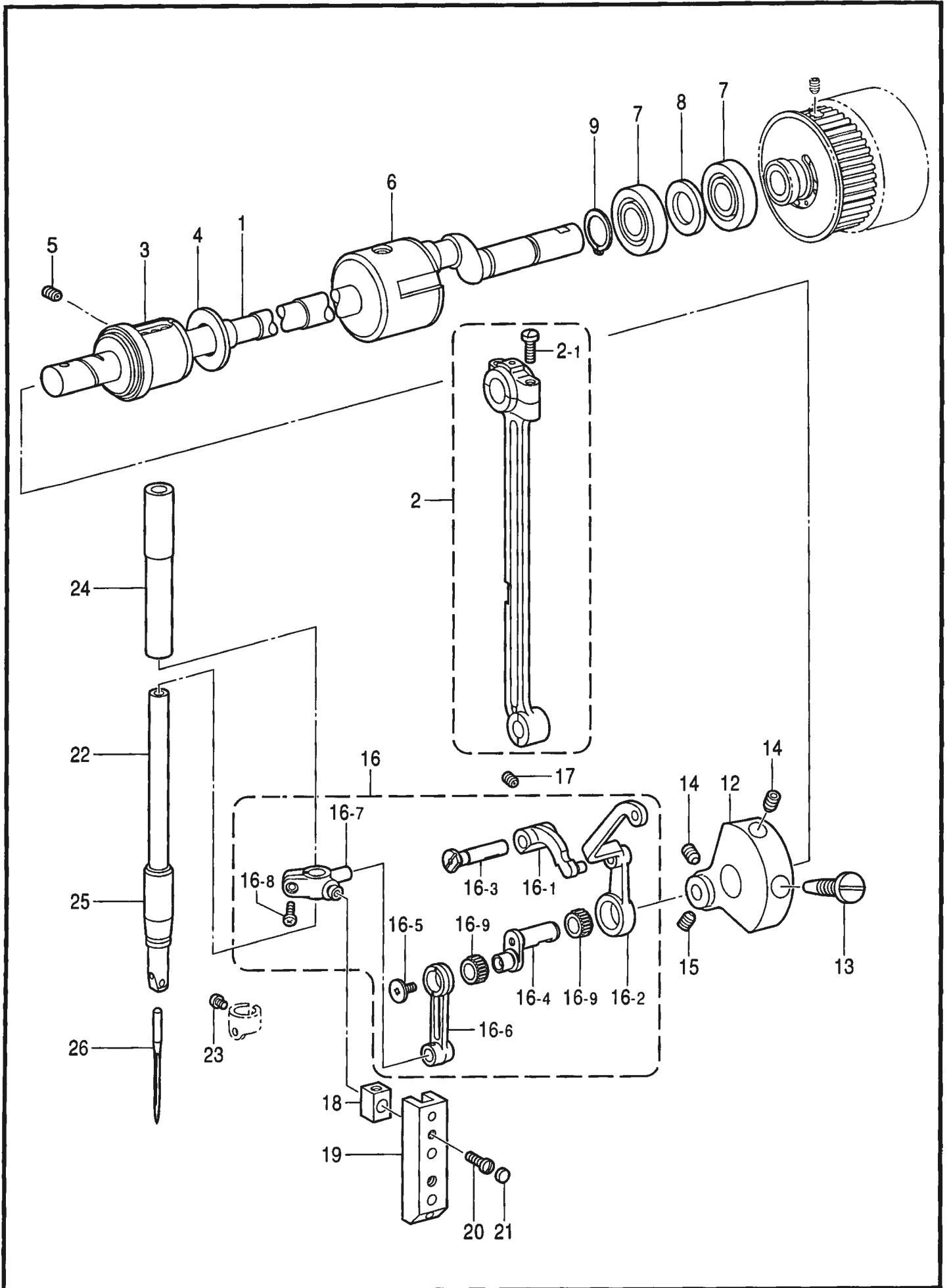

118-P34-123

B1 . 上軸・針棒関係 / Upper shaft and needle bar mechanism

REF.NO.	CODE	Q'TY	ヒンメイ	NAME OF PARTS	RM
1	S55103001	1	ウワシク	UPPER SHAFT	
2	S45147101	1	クランクロツトクミ	CRANK ROD ASSY	
2-1	144712001	2	シメネシ4.76	SCREW, SM4.76	
3	S49582001	1	ウワシクメタルF	BUSH, F ; U-SHAFT	
4	S55104001	1	スラストザカネ	WASHER, THRUST	
5	014780622	1	アナトメネシ6.35クホミ	SET SCREW, SOCKET (CP) SM6.35	
6	140726000	1	ウワシクメタルM	BUSH, M ; U-SHAFT	
7	072630260	2	ヘアリンク6302VV	BALL BEARING, 6302VV	
8	116920001	1	オクリシクスラストリンク	RING, THRUST	
9	048150142	1	トメワシクヨウC15	RETAINING RING, EXTERNAL C15	
12	S49584000	1	ツリアイクランクD	THREAD TAKE-UP CRANK, D	
13	100250001	1	シメネシ7.14	SCREW, SM7.14	
14	014770622	2	アナトメネシ6.35クホミ	SET SCREW, SOCKET (CP) SM6.35	
15	123006001	1	トメネシ6.35クホミ	SET SCREW, (CP) SM6.35	
16	S55105001	1	ハリボウレンカクミ	THREAD TAKE-UP LEVER ASSY	
16-1	S49587001	1	テンビンササエ	THREAD TAKE-UP SUPPORT	
16-2	S49588001	1	テンヒントウ	THREAD TAKE-UP LEVER	
16-3	S47091001	1	テンビンササエシク	SUPPORT SHAFT, ;T/TAKE-UP	
16-4	S49589001	1	ハリボウクランク	NEEDLE BAR CRANK	
16-5	145465001	1	シメネシ3.57L	SCREW, SM3.57-40X6 L	
16-6	S49689001	1	ハリボウレンカン	CONNECTING ROD, ;N-BAR	
16-7	S42756101	1	ハリボウダキ	NEEDLE BAR CLAMP	
16-8	062680712	1	ナベコ437-40X7	SCREW, PAN SM4.37-40X7	
16-9	147777000	2	ニードルベアリング	NEEDLE BEARING	
17	014780622	1	アナトメネジ6.35クホミ	SET SCREW, SOCKET (CP) SM6.35	
18	102630001	1	ハリボウアンナイカクコマ	SLIDE BLOCK, ;N-BAR GUIDE	
19	S49593000	1	ハリボウアンナイ	NEEDLE BAR GUIDE	
20	100242003	2	シメネジ3.57	SCREW, SM3.57-40X5	
21	155578000	2	ゴムセン7.2	RUBBER CAP, 7.2	
22	S02269001	1	ハリボウ	NEEDLE BAR	
23	144458001	1	アタマツキトメネジ3.57	SET SCREW, SM3.57-40X4.5	
24	152242001	1	ハリボウメタルU	BUSH, U ; N-BAR	
25	152243001	1	ハリボウメタルD	BUSH, D ; N-BAR	
26	※	1	ミシンハリ	NEEDLE	

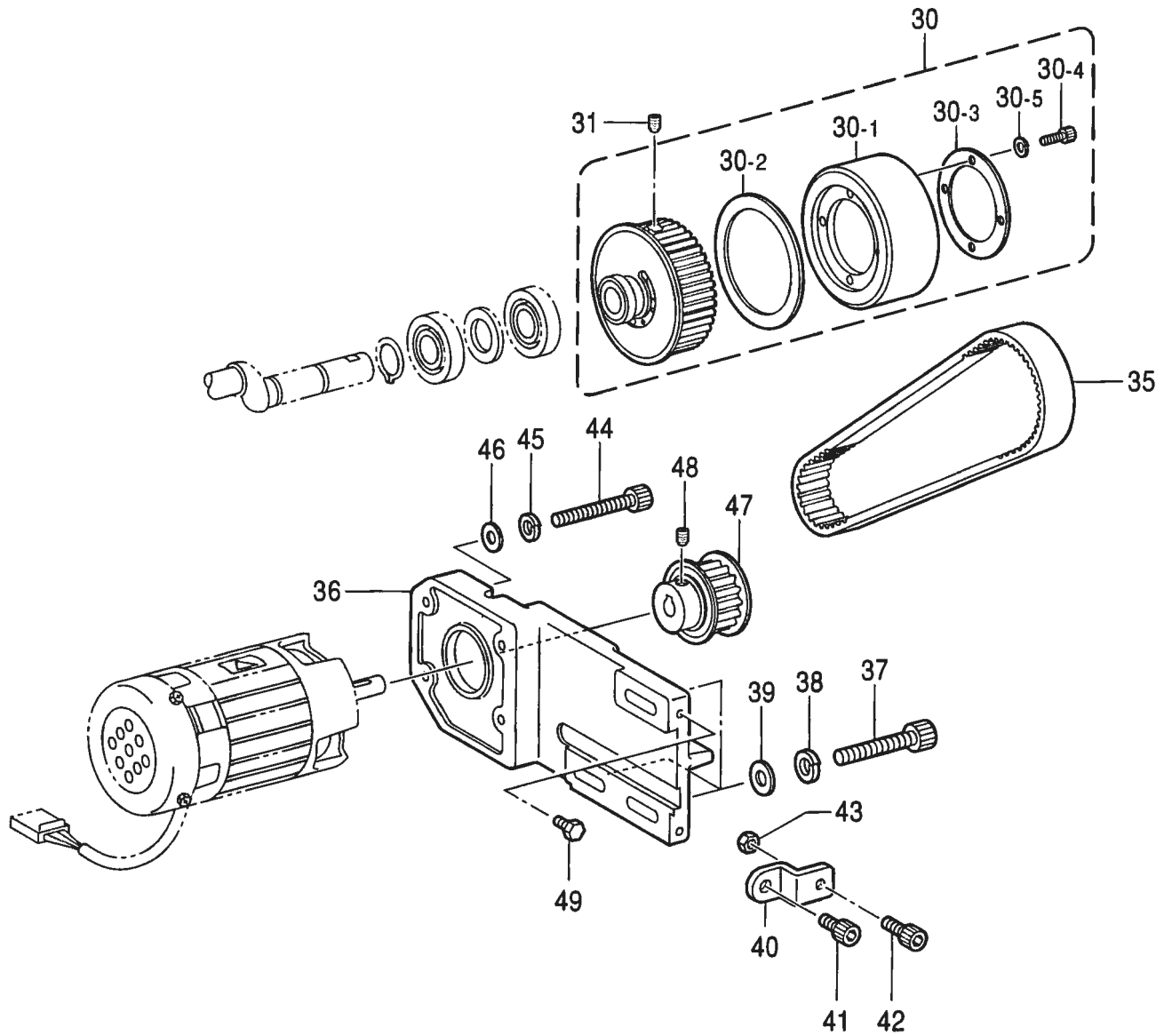

B2 . 上軸・針棒関係 / Upper shaft and needle bar mechanism

REF.NO.	CODE	Q'TY	ヒンメイ	NAME OF PARTS	RM
30	S52834201	1	Uタイミングプーリクミ	TIMING PULLEY ASSY, U	
30-1	S56017000	1	ウワシクプーリ	PULLEY, U-SHAFT	
30-2	S56018000	1	プーリスヘーサ	SPACER, PULLEY	
30-3	S56019001	1	プーリザガネ	WASHER, PULLEY	
30-4	018401236	3	アナボルト4X12	BOLT, SOCKET M4X12	
30-5	028040246	3	バネザガネ2-4	WASHER, SPRING 2-4	
31	S55572001	2	アナクホミ595-28X10	SET SCREW, SOCKET(CP)SM5.95X10	
35	S52838000	1	ウワシクタイミングヘルト	TIMING BELT, U-SHAFT	
36	S52839100	1	IMモータブラケット	MOTOR BRACKET, IM	
37	018083022	3	アナボルト8X30	BOLT, SOCKET M8X30	
38	028080242	3	バネザガネ2-8	WASHER, SPRING 2-8	
39	025080232	3	ヒラザガネチユウ8	WASHER, PLAIN M 8	
40	S52840001	1	ヘルトチヨウセツイタ	ADJUSTING PLATE, BELT	
41	018061022	1	アナボルト6X10	BOLT, SOCKET M6X10	
42	018062522	1	アナボルト6X25	BOLT, SOCKET M6X25	
43	021060102	1	ナツト1シユ6	NUT, 1 M6	
44	018063022	4	アナボルト6X30	BOLT, SOCKET M6X30	
45	028060242	4	バネザガネ2-6	WASHER, SPRING 2-6	
46	025060232	4	ヒラザガネチユウ6	WASHER, PLAIN M 6	
47	S52836000	1	モータタイミングプーリクミ	TIMING PULLEY ASSY, MOTOR	
48	S55572001	1	アナクホミ595-28X10	SET SCREW, SOCKET(CP)SM5.95X10	
49	017680512	1	ボルト4.37X5	BOLT, SM4.37X5	

C1 . 送り関係 / Feed mechanism

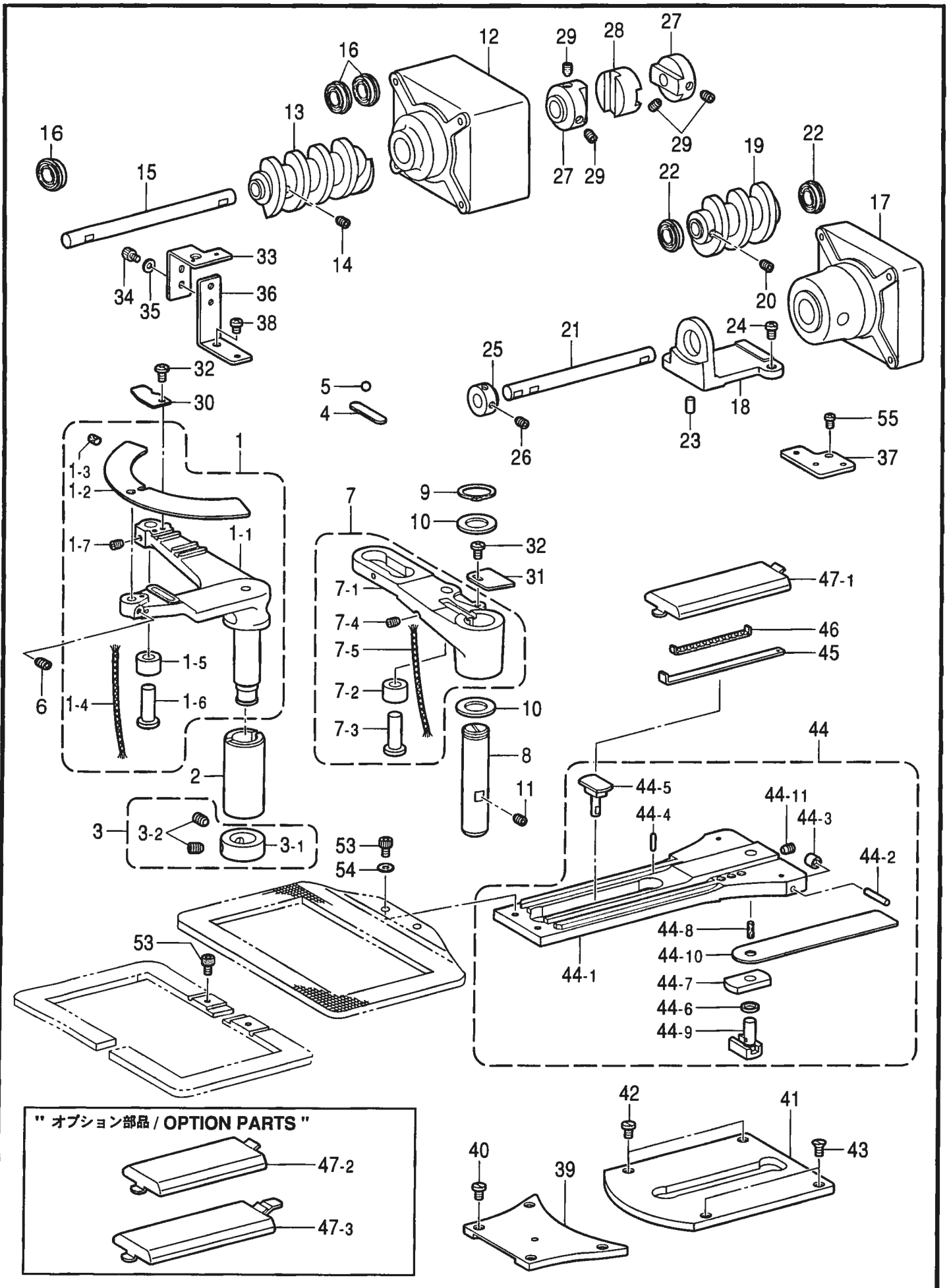

C1. 送り関係 / Feed mechanism

REF.NO.	CODE	Q'TY	ヒンメイ	NAME OF PARTS	RM
1	S51857001	1	Xオクリレバー100クミ	FEED LEVER ASSY, X ; 100	
1-1	S42067001	1	Xオクリレバー100	FEED LEVER, X ; 100	
1-2	S51858001	1	Xオクリレバーフタ	COVER, ;X-FEED LEVER	
1-3	153924001	1	フェルト	FELT	
1-4	108802001	1	クミヒモ4X4	WICK, 4X4 L = 250	
1-5	S37932101	1	オクリカムコロ	FEED CAM ROLLER	
1-6	S37933001	1	コロシク	ROLLER SHAFT	
1-7	014760622	1	アナトメネシ5.95	SET SCREW, SOCKET SM5.95	
2	S37934001	1	Xオクリレバーメタル	BUSH, ;X-FEED LEVER	
3	183493001	1	オクリシクセツトカラークミ	SET SCREW COLLAR ASSY	
3-1	S09212001	1	セツトカラー	SET SCREW COLLAR	
3-2	101706001	2	トメネシ6.35	SET SCREW, SM6.35-40X5.5	
4	153393001	1	ヨコオクリレバーカンザ	WASHER	
5	071047650	1	コウキユウ3/16	STEEL BALL, 3/16	
6	014760622	1	アナトメネシ5.95	SET SCREW, SOCKET SM5.95	
7	S42069001	1	Yオクリレバー60クミ	FEED LEVER ASSY, Y ; 60	
7-1	S42070001	1	Yオクリレバー60	FEED LEVER, Y ; 60	
7-2	S37932101	1	オクリカムコロ	FEED CAM ROLLER	
7-3	S37933001	1	コロシク	ROLLER SHAFT	
7-4	014760622	1	アナトメネシ5.95	SET SCREW, SOCKET SM5.95	
7-5	152973001	1	クミヒモ4X4	WICK, 4X4 L = 170	
8	152760051	1	タテオクリレバーシク	LEVER SHAFT	
9	048180142	1	トメワジクヨウC18	RETAINING RING, EXTERNAL C18	
10	152756001	2	スラストザカネ18	WASHER, THRUST 18	
11	014760622	1	アナトメネシ5.95	SET SCREW, SOCKET SM5.95	
12	S41703000	1	PMブラケットX	PM BRACKET, X	
13	S53099001	1	オクリカムX100	FEED CAM, X ; 100	
14	014760622	2	アナトメネシ5.95	SET SCREW, SOCKET SM5.95	
15	S41705001	1	カムジクX	CAM SHAFT, X	
16	070688850	3	タマジクウケ688ZZNR	BALL BEARING, 688ZZNR	
17	S51099000	1	PMブラケットY	PM BRACKET, Y	
18	S51100001	1	オクリカムブラケットY60	FEED CAM BRACKET, Y ; 60	
19	S53100001	1	オクリカムY60	FEED CAM, Y ; 60	
20	014760622	2	アナトメネシ5.95	SET SCREW, SOCKET SM5.95	
21	S51101001	1	カムジクY	CAM SHAFT, Y	
22	070688850	2	タマジクウケ688ZZNR	BALL BEARING, 688ZZNR	
23	S37940001	2	イチギメピン	POSITIONING PIN	
24	062681012	2	ナベコ437-40X10	SCREW, PAN SM4.37-40X10	
25	S51103001	1	セツトカラー	SET SCREW COLLAR	
26	014760622	2	アナトメネシ5.95	SET SCREW, SOCKET SM5.95	
27	S37942000	4	カツフリングハブ8	COUPLING HUB, 8	
28	S37944000	2	カツフリングスヘーサ	SPACER, COUPLING	
29	014760622	8	アナトメネシ5.95	SET SCREW, SOCKET SM5.95	
30	S51462001	1	ゲンテンドグX	HOME POSITION DOG, X	
31	S51463001	1	ゲンテンドグY	HOME POSITION DOG, Y	
32	060680712	2	バインド437-40X7	SCREW, BIND SM4.37-40X7	
33	S53108001	1	Xセンサートリツケイタ	SETTING PLATE, ;X-SENSOR	
34	018400632	1	アナボルト4X6	BOLT, SOCKET M4X6	
35	025040232	1	ヒラザガネチユウ4	WASHER, PLAIN M 4	
36	S53109001	1	Xセンサートリツケダイ	SETTING BASE, ;X-SENSOR	
37	S51465001	1	Yセンサートリツケイタ	SETTING PLATE, ;Y-SENSOR	
38	062680612	1	ナベコ4.37-40X6	SCREW, PAN SM4.37-40X6	
39	S51856001	1	オクリダイアンナイイタF	GUIDE PLATE, F ; FEED BRA.	
40	145318001	4	シメネジ4.37	SCREW, SM4.37	
41	S42083001	1	オクリダイアンナイイタR	GUIDE PLATE, R ; FEED BRA.	
42	145318001	2	シメネシ4.37	SCREW, SM4.37	
43	100032004	2	サラネシ4.37	SCREW, FLAT SM4.37-40X8	
44	S42084101	1	オクリダイクミ	FEED BRACKET ASSY	
44-1	156076101	1	オクリダイ	FEED BRACKET	

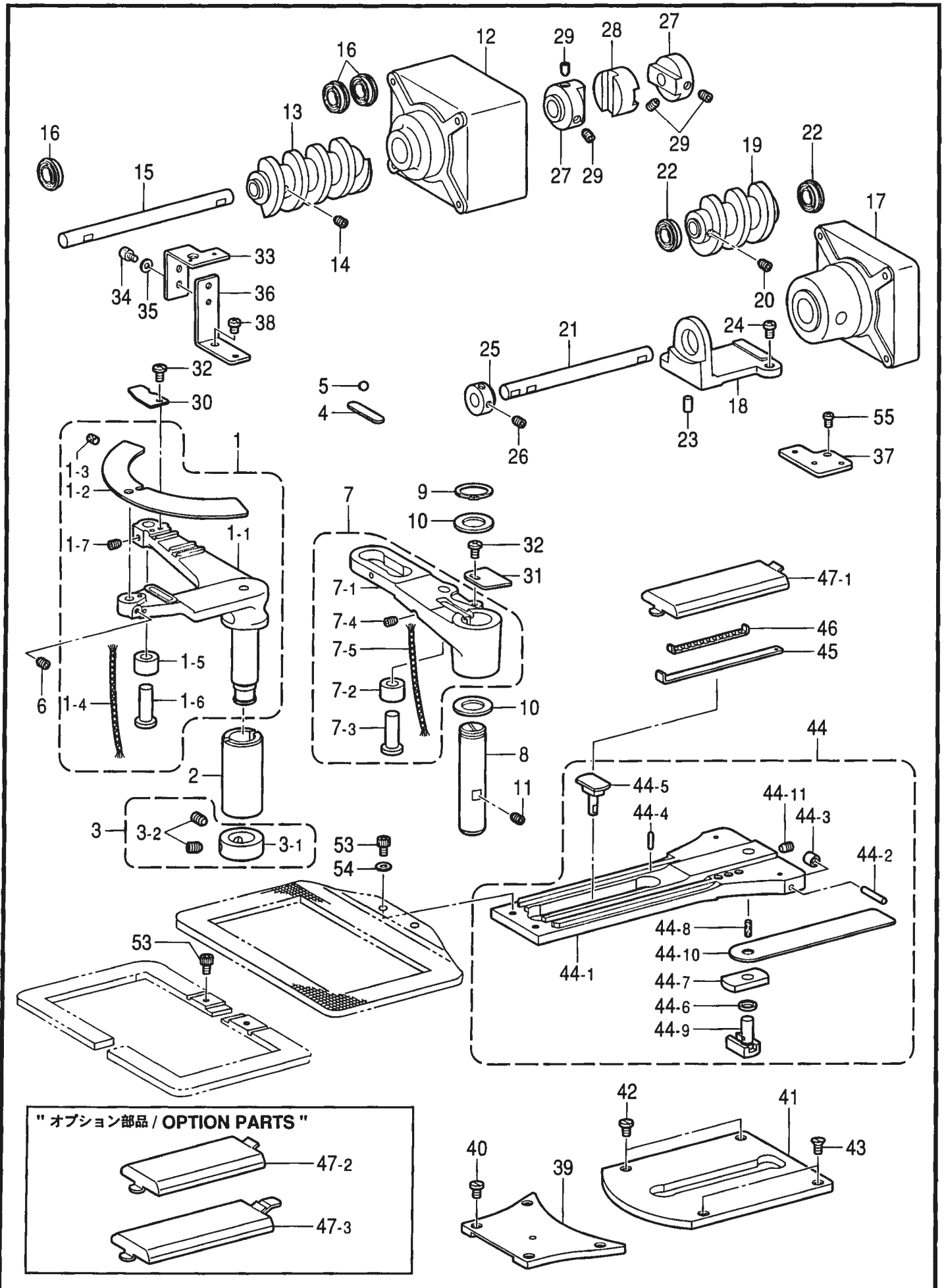

C1 . 送り関係 / Feed mechanism

REF.NO.	CODE	Q'TY	ヒンメイ	NAME OF PARTS	RM
44-2	153377001	2	コロA3X17.8	ROLLER, A 3X17.8	
44-3	153378001	2	オクリダイコロ	FEED GUIDE ROLLER	
44-4	148133001	2	コロ	ROLLER	
44-5	156108001	1	タテオクリカクコマクミ	T-WIDTH REGULATOR BLOCK ASSY	
44-6	156109001	1	カンザ	SPACER	
44-7	156077001	1	オクリダイカクコマ	FEED GUIDE SLIDE BLOCK	
44-8	156080000	1	フェルト	FELT	
44-9	153380001	1	ヨコオクリカクコマクミ	T-LENGTH REGULATOR BLOCK ASSY	
44-10	S42086001	1	Yオクリレバーフタ	COVER, Y-FEED LEVER	
44-11	014760622	1	アナトメネジ5.95	SET SCREW, SOCKET SM5.95	
45	153383001	2	オクリダイカンザ	FEED BRACKET WASHER	
46	153384001	2	リテーナークミ	RETAINER ASSY	
47-1	153391001	1	オクリダイカバーL	FEED BRACKET COVER, L	
53	018680522	4	アナボルト4.37X5	BOLT, SOCKET SM4.37X5	
54	025680232	2	ヒラザガネチユウ4.37	WASHER, PLAIN M 4.37	
55	062670612	1	ナベコ357-40X6	SCREW, PAN SM3.57-40X6	
47-2	153392001	1	" オプション部品 "	" OPTION PARTS "	
47-3	S51860001	1	オクリダイカバーS	FEED BRACKET COVER, S	
		1	オクリダイカバーLLクミ	COVER ASSY, LL ; F-BRA. GUIDE	

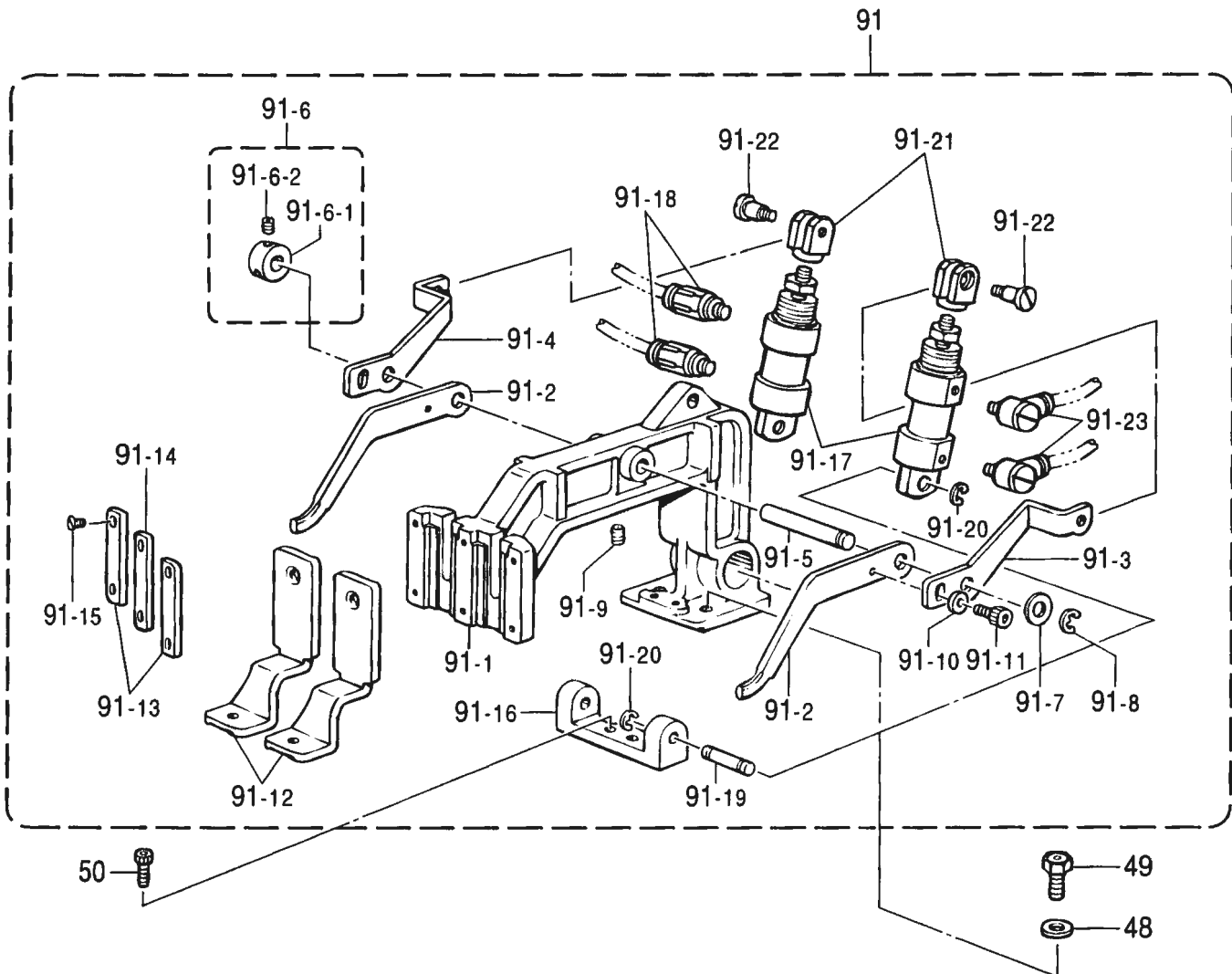

"オプション部品 / OPTION PARTS"

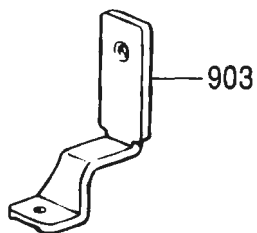

C2 . 送り関係 / Feed mechanism

REF.NO.	CODE	Q'TY	ヒンメイ	NAME OF PARTS	RM
48	025060232	2	ヒラザガネチユウ6	WASHER, PLAIN M 6	
49	S39110001	2	ホルト595-28X14	BOLT, W/SOCKET SM5.95-28X14	
50	018501022	2	アナボルト5X10	BOLT, SOCKET M5X10	
91	S53091001	1	オサエウテクミ434Eエア-	WORK CLAMP ARM ASSY, 434E AIR	
91-1	S41658000	1	オサエウテZ34エア-	WORK CLAMP ARM, Z34 AIR	
91-2	S53092001	2	オサエウテレバーF	WORK CLAMP ARM LEVER, F	
91-3	S10377101	1	オサエウデレバーRR	WORK CLAMP ARM LEVER, RR	
91-4	S10378101	1	オサエウデレバーRL	WORK CLAMP ARM LEVER, RL	
91-5	S10058001	1	オサエウデレバーシク	LEVER SHAFT, ;W-CLAMP ARM	
91-6	S21775001	1	セツトカラークミ	SET SCREW COLLAR ASSY	
91-6-1	139096001	1	セツトカラ-	SET SCREW COLLAR	
91-6-2	014680622	2	アナトメネジ4.37クホミ	SET SCREW, SOCKET (CP) SM4.37	
91-7	143591001	1	スラストリング	RING, THRUST	
91-8	048050342	1	トメワE5	RETAINING RING, E5	
91-9	014760622	1	アナトメネジ5.95	SET SCREW, SOCKET SM5.95	
91-10	025040232	2	ヒラザガネチユウ4	WASHER, PLAIN M 4	
91-11	018400622	2	アナボルト4X6	BOLT, SOCKET M4X6	
91-12	S41660001	2	オサエアシ434Eエア-	WORK CLAMP, 434E AIR	
91-13	153369001	2	オサエアシオサエイタA	WORK CLAMP GUIDE PLATE, A	
91-14	153370001	1	オサエアシオサエイタB	WORK CLAMP GUIDE PLATE, B	
91-15	107038003	6	サラネジ3.57	SCREW, FLAT SM3.57	
91-16	S53094001	1	シリンダササエ	CYLINDER SUPPORT	
91-17	S53095000	2	エアシリンダ15-18	AIR CYLINDER, ;15-18	
91-18	S18415101	2	ハーフユニオンQ4M5	HALF UNION, ;Q4M5	
91-19	S03800001	2	クレビスヒン	CLEVIS PIN	
91-20	048040342	4	トメワE4	RETAINING RING, E4	
91-21	S53096001	2	シリンダツギテ	CYLINDER JOINT	
91-22	110168001	2	コロジク	ROLLER SHAFT	
91-23	S41271000	2	エルボM5	ELBOW, M5	
903	S51102001	1	" オフション部品 " オサエアシ434EMK2エア-	" OPTION PARTS " WORK CLAMP, 434EMK2 AIR	

< ゲージ部品 / Gauge parts >

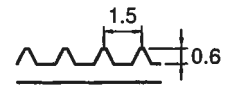
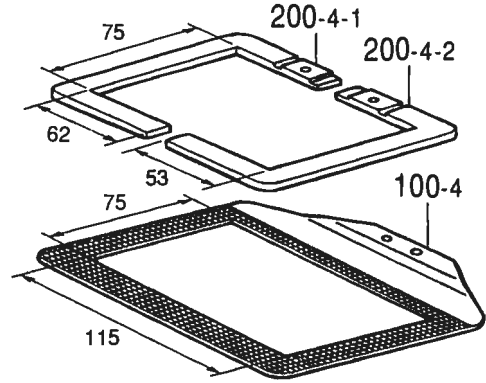
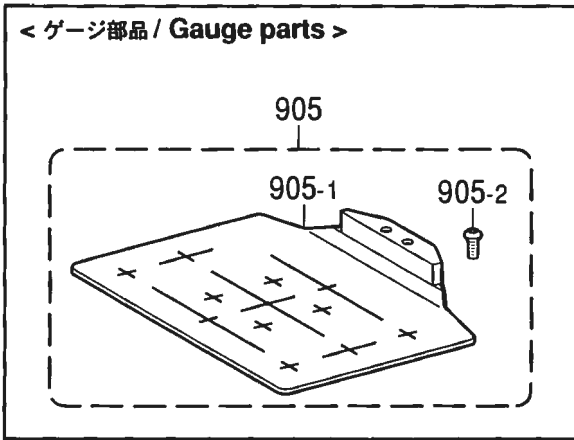

" オプション部品 / OPTION PARTS "

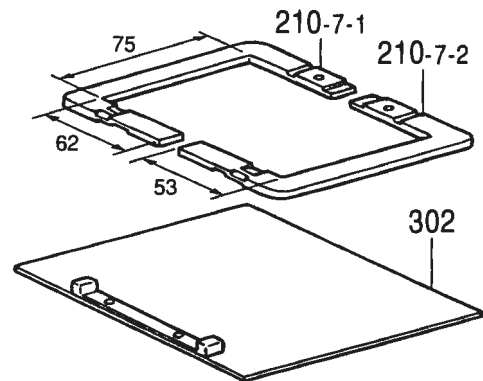
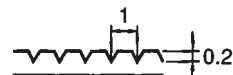
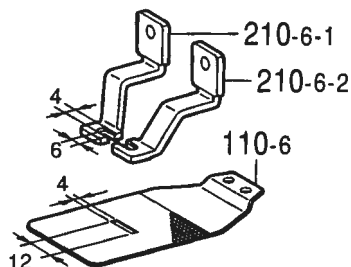
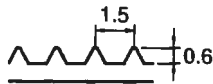
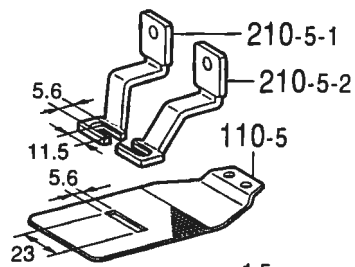
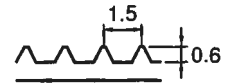
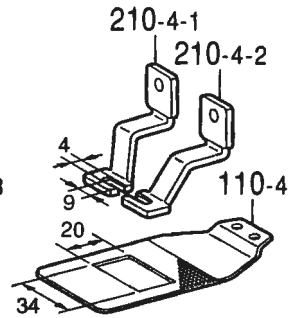
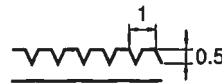
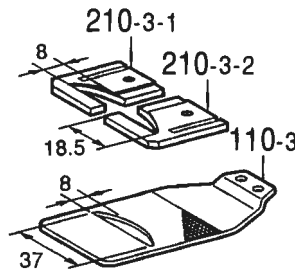
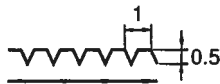
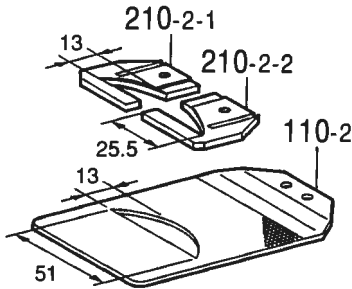
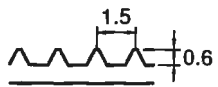
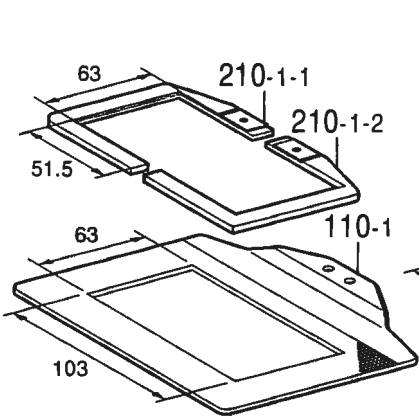

C3. 送り関係 / Feed mechanism

REF.NO.	CODE	Q'TY	ヒンメイ	NAME OF PARTS	RM
100-4 200-4-1 200-4-2	S44942001 S46545001 S46544001	1 1 1	オクリイタ434ESF-2 オサエヒダリ434ESF-2 オサエミギ434ESF-2	FEED PLATE, 434ESF-2 WORK CLAMP, LEFT 434ESF-2 WORK CLAMP, RIGHT 434ESF-2	
110-1 210-1-1 210-1-2	153503001 153498001 153493001	1 1 1	オクリイタ オサエヒダリ オサエミギ	" OPTION PARTS " <For "100X60"> FEED PLATE WORK CLAMP, LEFT WORK CLAMP, R	
110-2 210-2-1 210-2-2	S23379001 S23378001 S23377001	1 1 1	<48X10XR30用> オクリイタ434-519 オサエヒダリ434-519 オサエミギ434-519	<For "48X10XR30"> FEED PLATE, 434-519 WORK CLAMP, LEFT 434-519 WORK CLAMP, RIGHT 434-519	
110-3 210-3-1 210-3-2	S27838001 S27837001 S27836001	1 1 1	<34X5XR28用> オクリイタ434-895 オサエヒダリ434-895 オサエミギ434-895	<For "34X5XR28"> FEED PLATE, 434-895 WORK CLAMP, LEFT 434-895 WORK CLAMP, 434-895	
110-4 210-4-1 210-4-2	156087001 156086001 156085001	1 1 1	<門止縫い16X2用> オクリイタ オサエアシLM オサエアシRM	<For Sewing the bar tack "16X2"> FEED PLATE WORK CLAMP, LM WORK CLAMP, RM	
110-5 210-5-1 210-5-2	156084001 156083001 156082001	1 1 1	<門止縫い20X3用> オクリイタL オサエアシLL オサエアシRL	<For Sewing the bar tack "20X3"> FEED PLATE, L WORK CLAMP, LL WORK CLAMP, RL	
110-6 210-6-1 210-6-2	156090001 156089001 156088001	1 1 1	<門止縫い10X2用> オクリイタS オサエアシLS オサエアシRS	<For Sewing the bar tack "10X2"> FEED PLATE, S WORK CLAMP, LS WORK CLAMP, RS	
210-7-1 210-7-2	S44941001 S44940001	1 1	<ワンタッチ押え板用> オサエヒダリ434ESF オサエミギ434ESF	<For one touch work clamp> WORK CLAMP, LEFT 434ESF WORK CLAMP, RIGHT 434ESF	
302 302 302	S43990001 S43991001 S43992001	1 1 1	<ワンタッチ押え板組> OTオサエイタ434EAクミ <t=0.5> OTオサエイタ434EBクミ <t=1.0> OTオサエイタ434ECクミ <t=2.0>	<One touch work clamp assy> OT WORK CLAMP ASSY, A 434E ... <t=0.5> OT WORK CLAMP ASSY, B 434E ... <t=1.0> OT WORK CLAMP ASSY, C 434E ... <t=2.0>	
905 905-1 905-2	S54984001 S52100001 S49955001	1 1 2	<ゲージ部品> ゲージクミ434EMK2 ゲンテンキジユニイタ オクリイタシメネジ	<Gauge parts> GUAGE ASSY, 434EMK2 HOME POSITION STANDARD PLATE SCREW, W/SOCKET SM4.37	

D. 押工上げ関係 / Work clamp lifter mechanism

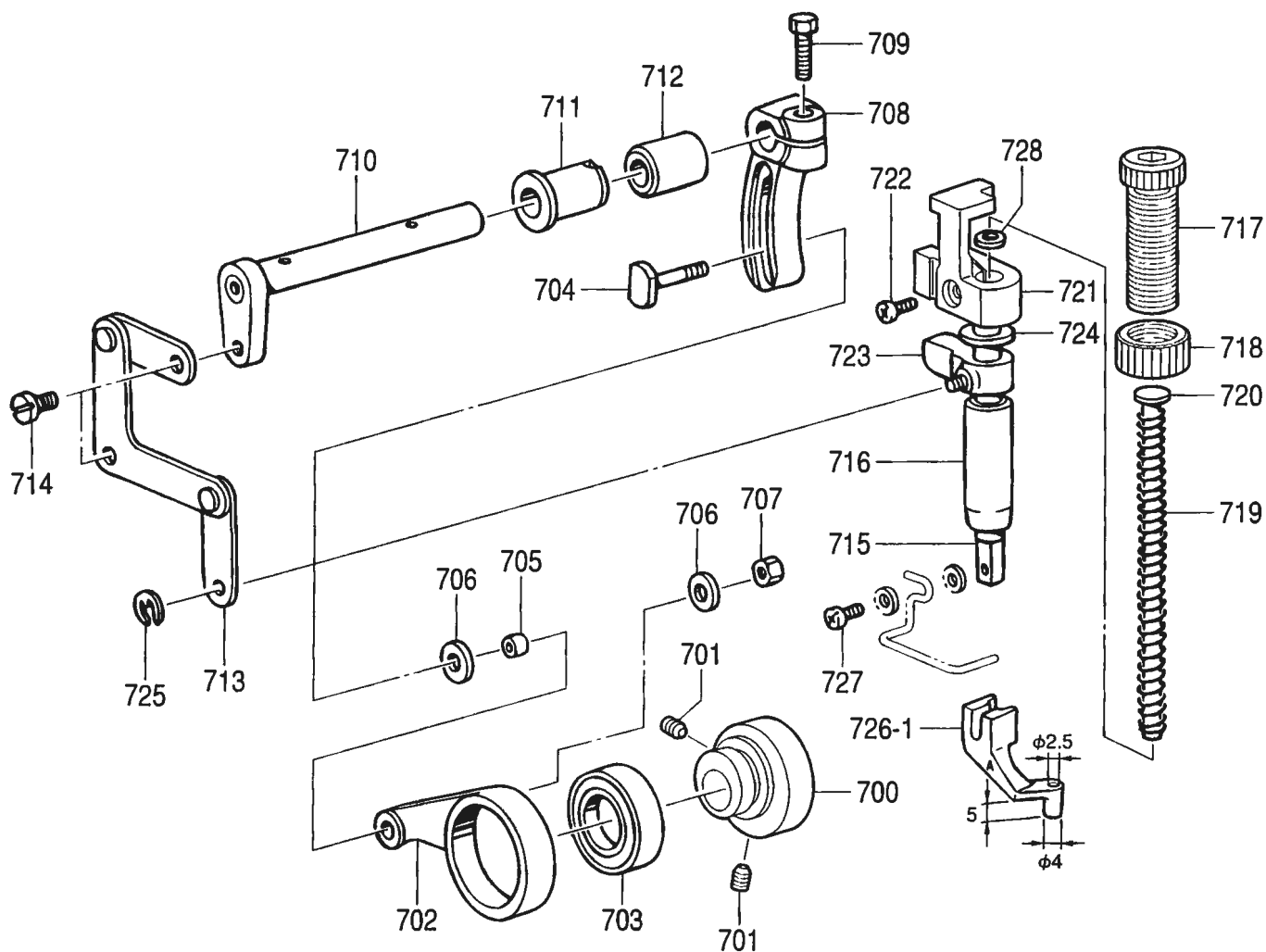

" オプション部品 / OPTION PARTS "

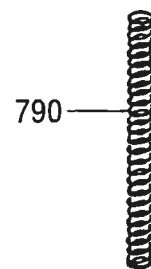
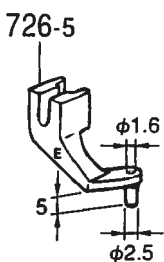
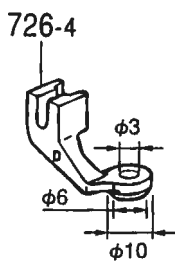
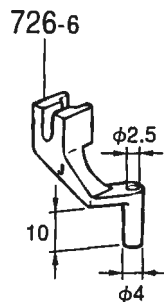
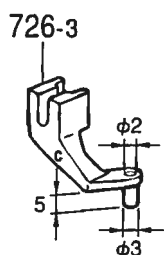
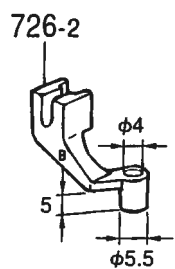

D. 押エ上ゲ関係 / Work clamp lifter mechanism

REF.NO.	CODE	Q'TY	ヒンメイ	NAME OF PARTS	RM
700	S55107001	1	カンケツオサエカムB	STEPPING WORK CLAMP CAM, B	
701	014770632	2	アナクホミ 635-40X6	SET SCREW, SOCKET(CP) SM6.35X6	
702	S43693000	1	カンケツオサエレンカン	STEPPING WORK CLAMP CON. ROD	
703	623033000	1	タマシクウケ6805VV	BALL BEARING, 6805VV	
704	150460001	1	U-UDオクリレバーシク	U-UD FEED LIFTER LEVER SHAFT	
705	150461001	1	オクリコロ	FEED ROLLER	
706	107453001	2	ザガネ	WASHER	
707	021750102	1	1シユナツト556-32	NUT, 1 SM5.56-32	
708	S17871101	1	カンケツオサエウデR	STEPPING WORK CLAMP ARM, R	
709	017751412	1	ボルト5.56X14	BOLT, SM5.56X14	
710	S42839101	1	カンケツオサエウデF	STEPPING WORK CLAMP ARM, F	
711	148196000	1	ウワメスサドウウデメタルL	BUSH, L	
712	148197000	1	ウワメスサドウウデメタルR	BUSH, R	
713	S42840101	1	カンケツリンククミ	STEPPING LINK ASSY	
714	155167002	2	ダンネジ5.56	SHOULDER SCREW, SM5.56	
715	S42880001	1	オサエボウヨコ	PRESSER BAR, SIDE	
716	145472001	1	オサエボウメタル	BUSH, P-BAR	
717	S31012001	1	オサエチヨウセツネシ	ADJUSTING SCREW, PRESSER	
718	S31013001	1	チヨウセツネジツマミナツト	ADJUSTING NUT, PRESSER	
719	S10111101	1	オサエバネ	SPRING, COMPRESSION	
720	S10112001	1	オサエバネアンナイ	SPRING GUIDE	
721	S10113301	1	オサエホウダキ	GUIDE BRACKET, ;P-BAR	
722	062681212	1	ナベコ437-40X12	SCREW, PAN SM4.37-40X12	
723	S10371001	1	オサエホウリフター	PRESSER BAR LIFTER	
724	S10372100	1	オサエホウダキクツシヨン	CUSHION	
725	048040342	1	トメワE4	RETAINING RING, E4	
726-1	S42849101	1	オサエアシXA	WORK CLAMP, XA	
727	S13399001	1	シメネシ3 57X12	SCREW, SM3.57X12	
728	S03677001	1	ザガネ	WASHER	
726-2	S45131001	1	オフシヨン部品 " "	" OPTION PARTS "	
726-3	S45132001	1	オサエアシXB	WORK CLAMP, XB	
726-4	S45133001	1	オサエアシXC	WORK CLAMP, XC	
726-5	S45134001	1	オサエアシXD	WORK CLAMP, XD	
726-6	S45135001	1	オサエアシXE	WORK CLAMP, XE	
726-6	S45135001	1	オサエアシXJ	WORK CLAMP, XJ	
790	S33251001	1	オサエバネ	SPRING, COMPRESSION	

E. 下軸関係 / Lower shaft mechanism

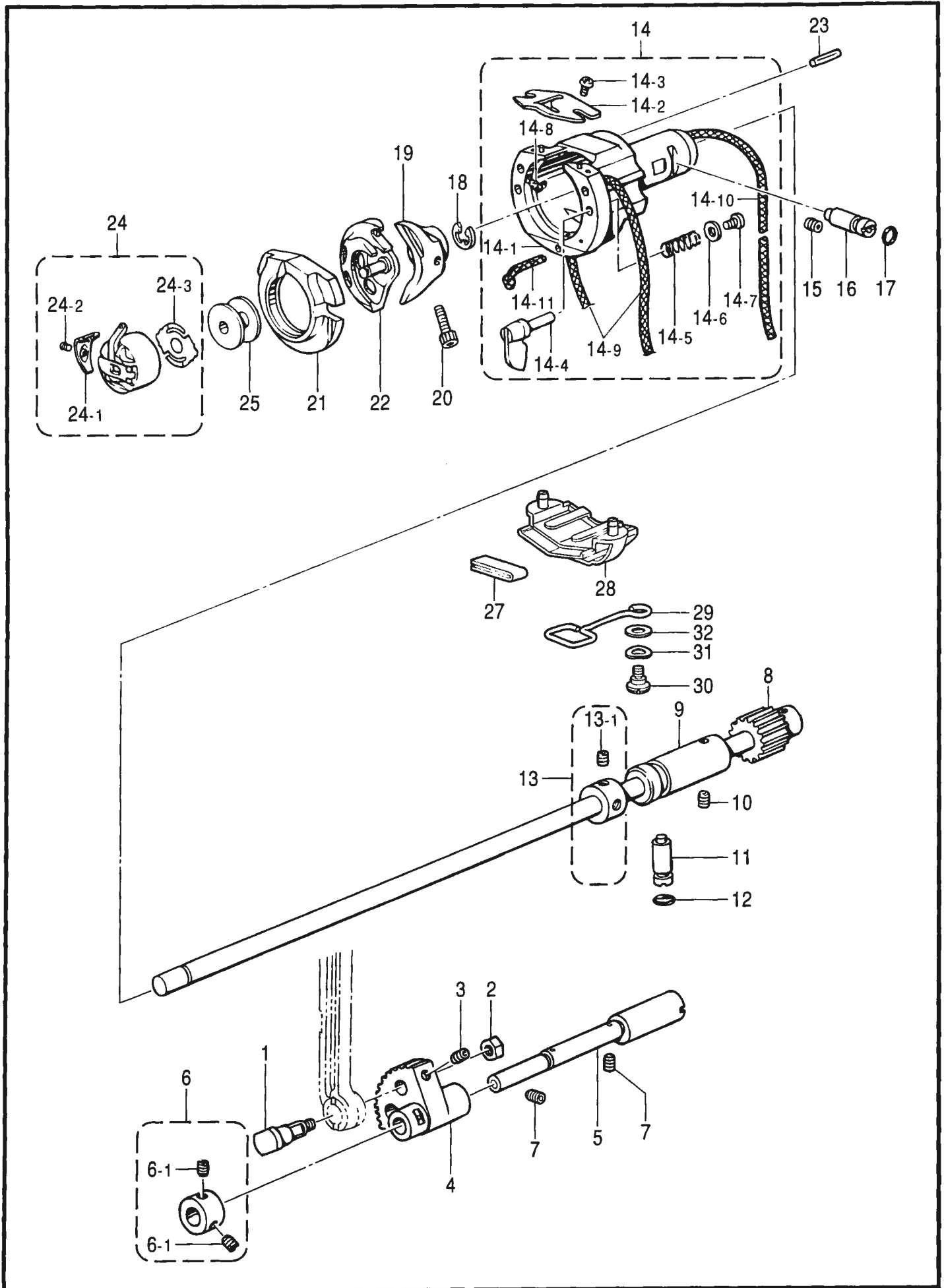

E. 下軸関係 / Lower shaft mechanism

REF.NO.	CODE	Q'TY	ヒンメイ	NAME OF PARTS	RM
1	141786001	1	クランクロツトダンネシ	SHOULDER SCREW, ;CRANK ROD	
2	100090004	1	ナツト7.14	NUT, SM7.14	
3	014680622	1	アナトメネシ4.37クホミ	SET SCREW, SOCKET (CP) SM4.37	
4	152245101	1	ヨウドウキヤ	ROCKER GEAR	
5	S37978251	1	ヨウトウギヤシク	SHAFT, ;R-GEAR	
6	181995001	1	セツトカラークミ	SET SCREW COLLAR ASSY	
6-1	101706001	2	トメネシ6.35	SET SCREW, SM6.35-40X5.5	
7	014760622	2	アナトメネシ5.95	SET SCREW, SOCKET SM5.95	
8	S53207001	1	シタシククミ	LOWER	
9	S49608001	1	シタシクメタル	BUSH, ;L-SHAFT	
10	014760622	1	アナトメネシ5.95	SET SCREW, SOCKET SM5.95	
11	152678201	1	カマチヨウセツシク	ADJUSTING STUD	
12	081003670	1	OリングPW3	O RING, PW3	
13	S49609001	1	セツトカラークミ	SET SCREW COLLAR ASSY	
13-1	014770622	2	アナトメネシ6.35クホミ	SET SCREW, SOCKET (CP) SM6.35	
14	S55927001	1	オオカマタイクミ	SHUTTLE RACE BASE ASSY	
14-1	S55216001	1	オオカマタイ	SHUTTLE RACE BASE	
14-2	S02429101	1	カマイトアンナイ	THREAD GUIDE, ;S-RACE	
14-3	062660412	2	ナベコ318-40X4	SCREW, PAN SM3.18-40X4	
14-4	152683101	2	オオカマトリツケツメ	SETTING CLAW, S-RACE BODY	
14-5	152684101	2	オオカマトリツケバネ	SPRING, COMPRESSION	
14-6	402887001	2	ザガネ3.2	WASHER, 3.2	
14-7	062660712	2	ナヘコ318-40X7	SCREW, PAN SM3.18-40X7	
14-8	S09043000	2	フェルト	FELT	
14-9	S49981000	2	クミヒモ3X3	WICK, 3X3 L = 360	
14-10	S49626000	1	クミヒモ3X3	WICK, 3X3 L = 300	
14-11	S49685000	1	クミヒモ3X3	WICK, 3X3 L = 100	
15	014760622	1	アナトメネシ5.95	SET SCREW, SOCKET SM5.95	
16	152678201	1	カマチヨウセツシク	ADJUSTING STUD	
17	081003670	1	OリングPW3	O RING, PW3	
18	048070342	1	トメフE7	RETAINING RING, E7	
19	S55215001	1	トライバーHR	DRIVER, HR	
20	018501422	1	アナホルト5X14	BOLT, SOCKET M5X14	
21	※	1	オオカマ	SHUTTLE RACE BODY	
22	※	1	ナカカマハコクミ	SHUTTLE HOOK ASSY, W/BOX	
23	S16290001	1	ニードルローラー4X19.8	NEEDLE ROLLER, 4X19.8	
24	※	1	ボビンケースクミ	BOBBIN CASE ASSY	
24-1	※	1	ボビンケースチヨウシバネ	TENSION SPRING	
24-2	※	1	ボビンケースバネネジ	SCREW	
24-3	※	1	クウテンボウシバネ	SPRING, ANTI-SPIN	
25	※	1	ボビン	BOBBIN	
27	S55658000	1	カマフェルト	FELT	
28	S55214000	1	カマフェルトササエ	FELT HOLDER	
29	S55140001	1	サホート	SUPPORT	
30	123882001	1	ダンネジ4.37	SHOULDER SCREW, SM4.37	
31	103810002	1	ナミガタバネザガネ	WASHER, WAVE SPRING	
32	025770232	1	ヒラザガネチユウ6.35	WASHER, PLAIN M 6.35	

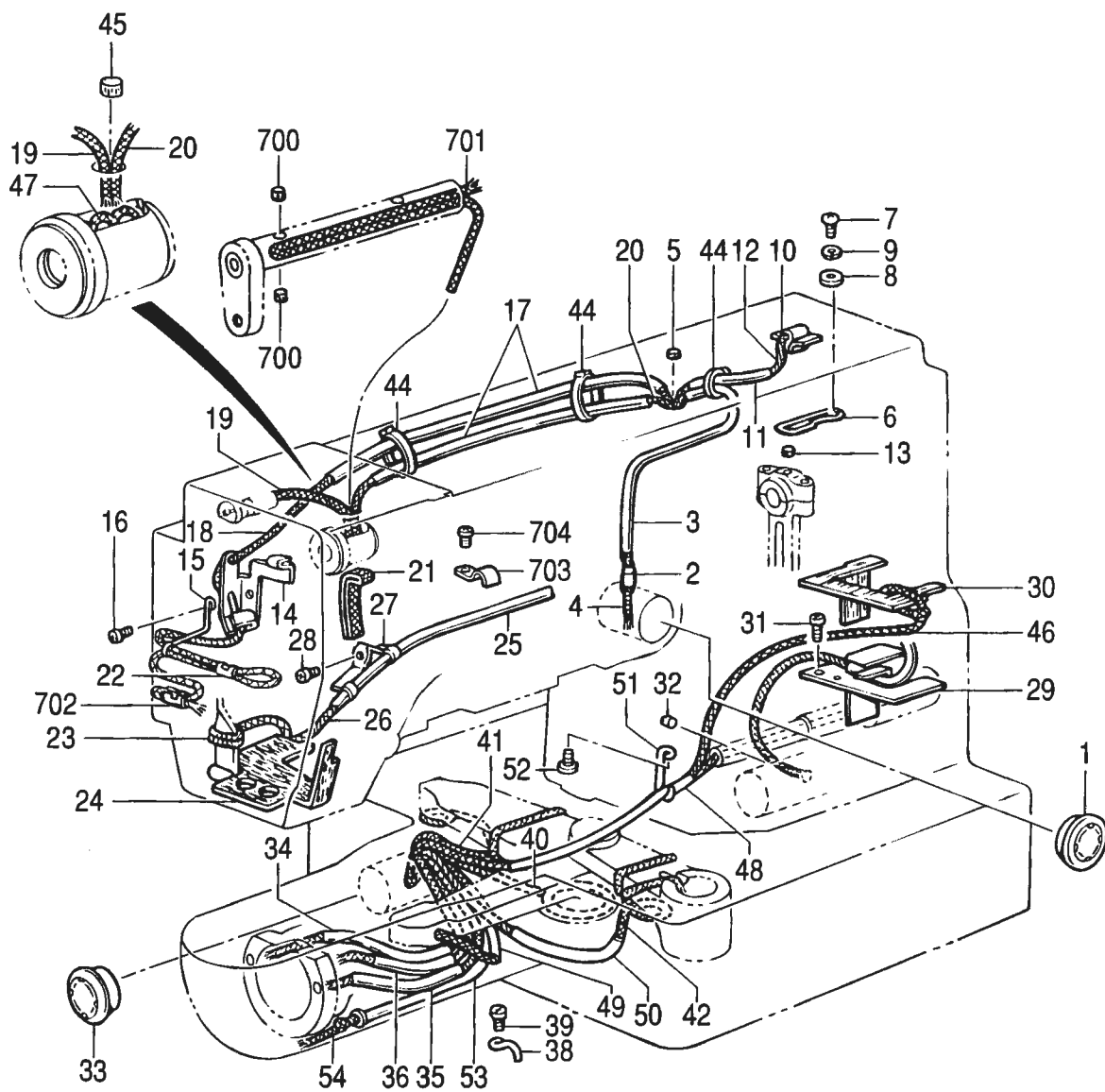

F. 給油潤滑関係 / Lubrication

REF.NO.	CODE	Q'TY	ヒンメイ	NAME OF PARTS	RM
1	S49992000	1	オイルホツトマト	OIL WINDOW	
2	S07333001	1	オイルクチハイフS	PIPE, S	
3	S07456000	1	ビニールチューブ	OIL TUBE, L = 160	
4	148738000	1	クミヒモ	WICK, L = 335	
5	107149001	1	フェルト	FELT	
6	S37983001	1	ウワシクキュウユササエ	WICK SUPPORT	
7	062680612	1	ナベコ4.37-40X6	SCREW, PAN SM4.37-40X6	
8	025680232	1	ヒラザガネチユウ4 37	WASHER, PLAIN M 4.37	
9	028680242	1	バネザガネ2-4 37	WASHER, SPRING 2-4.37	
10	S10478000	1	ロツドキュウユフェルト	FELT	
11	S34986000	1	ビニルチューブ	OIL TUBE, L = 135	
12	S49982000	1	クミヒモ4X4	WICK, 4X4 L = 400	
13	107149001	2	フェルト	FELT	
14	S49959001	1	テンピンキュウユササエ	WICK SUPPORT	
15	S10162201	1	ハリボウヒモササエ	WICK SUPPORT	
16	060670512	1	バインド357-40X5	SCREW, BIND SM3.57-40X5	
17	S49620000	2	ビニルチューブ	OIL TUBE, L = 340	
18	S49957000	1	クミヒモ4X4	WICK, 4X4 L = 700	
19	S49622000	1	クミヒモ4X4	WICK, 4X4 L = 130	
20	S49983000	1	クミヒモ4X4	WICK, 4X4 L = 800	
21	S49984000	1	ヒラクミヒモ	FLAT WICK, L = 200	
22	104567001	1	クミヒモササエ	WICK SUPPORT	
23	159565000	1	クミヒモ2.5X150	WICK, L = 150	
24	S42827100	1	スイアケフェルト	FELT	
25	S37986000	1	ビニルチューブ	OIL TUBE, L = 440	
26	S18093100	1	クミヒモ4X4	WICK, 4X4 L = 1100	
27	145547001	1	チューブホルダ	TUBE HOLDER	
28	062670512	1	ナヘコ357-40X5	SCREW, PAN SM3.57-40X5	
29	S37987001	1	シタシクキュウユササエ	FELT SUPPORT	
30	S37988000	1	シタシクキュウユフェルト	FELT	
31	062680612	1	ナヘコ4.37-40X6	SCREW, PAN SM4.37-40X6	
32	S09043000	1	フェルト	FELT	
33	152948001	1	オイルホツトマト	OIL WINDOW	
34	S49623000	1	ビニルチューブ	OIL TUBE, L = 280	
35	S49624000	1	ビニルチューブ	OIL TUBE, C ; L = 260	
36	S49625000	1	ビニルチューブ	OIL TUBE, L = 160	
38	152969001	2	コートササエカネ	CORD SUPPORT	
39	062670512	2	ナヘコ357-40X5	SCREW, PAN SM3.57-40X5	
40	148738000	1	クミヒモ	WICK, L = 335	
41	148738000	1	クミヒモ	WICK, L = 335	
42	152956001	1	クミヒモ4X4	WICK, 4X4 L = 500	
44	228475000	3	ケツソクバンド1.9X80	FASTENING BAND, 1.9X80	
45	153924001	1	フェルト	FELT	
46	S49957000	1	クミヒモ4X4	WICK, 4X4 L = 700	
47	S49958000	1	クミヒモ4X4	WICK, 4X4 L = 70	
48	S49985000	1	ビニルチューブ	OIL TUBE, L = 170	
49	S49986000	1	ビニルチューブ	OIL TUBE, L = 110	
50	S49987000	1	ビニルチューブ	OIL TUBE, L = 150	
51	S49995001	1	コートササエカネ	CORD SUPPORT	
52	062670512	1	ナヘコ357-40X5	SCREW, PAN SM3.57-40X5	
53	S49618000	1	ビニールチューブ	OIL TUBE, L = 210	
54	S55659000	1	クミヒモ	WICK, L = 600	
700	S09043000	2	フェルト	FELT	
701	108802001	1	クミヒモ4X4	WICK, 4X4 L = 250	
702	104567001	1	クミヒモササエ	WICK SUPPORT	
703	140647101	1	コードオサエ	CORD HOLDER	
704	062670612	1	ナヘコ357-40X6	SCREW, PAN SM3.57-40X6	

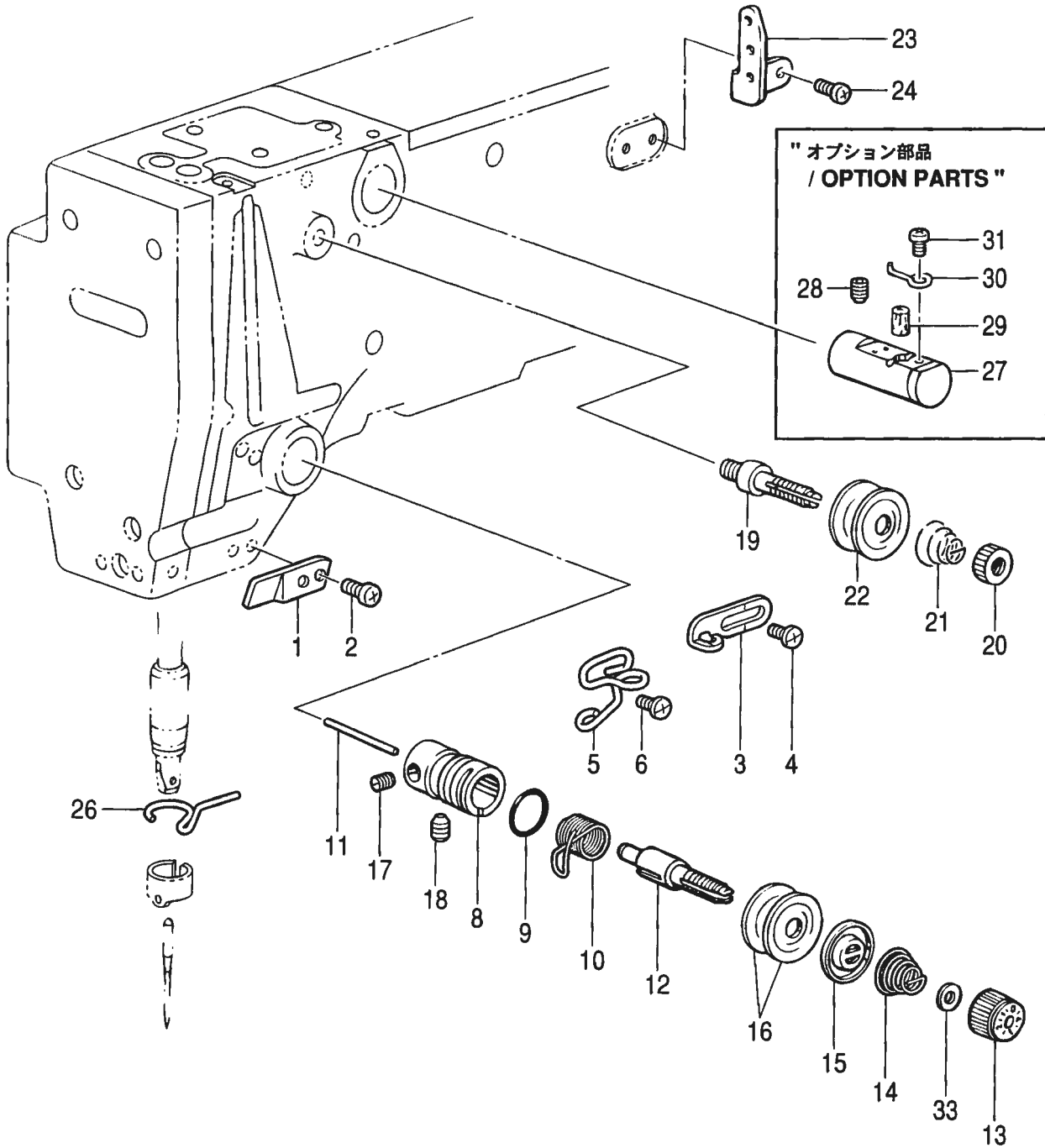

< 中厚物用
/ For Medium-weight materials >

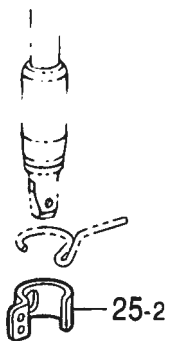

< 厚物用
/ For Heavy-weight materials >

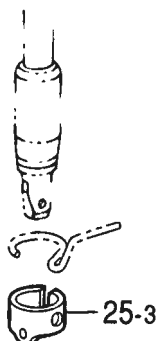

"オプション部品 / OPTION PARTS"
< 極厚物用
/ For Extra heavy-weight materials >

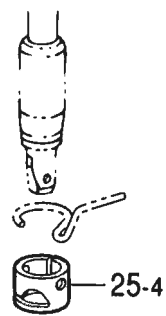

G. 糸通シ関係 / Threading mechanism

REF.NO.	CODE	Q'TY	ヒンメイ	NAME OF PARTS	RM
1	S53097001	1	アームイトミチ	ARM THREAD GUIDE	
2	062710612	1	ナベコ476-32X6	SCREW, PAN SM4.76-32X6	
3	S49627001	1	アームイトカケ	THREAD GUIDE, ;ARM	
4	060670612	1	バインド357-40X6	SCREW, BIND SM3.57-40X6	
5	S51859101	1	アームイトアンナイ	THREAD GUIDE, ;ARM	
6	060670612	1	バインド357-40X6	SCREW, BIND SM3.57-40X6	
8	152872001	1	イトチヨウシダイ	TENSION BRACKET	
9	114294001	1	Oリング	O RING	
10	※	1	イトトリバネ	THREAD TAKE-UP SPRING	
11	S12699000	1	イトユルメヒン	TENSION RELEASE PIN	
12	116922001	1	イトチヨウシボウ	TENSION STUD	
13	S31032001	1	イトチヨウシナツト	TENSION NUT	
14	※	1	イトチヨウシバネ	SPRING, TENSION	
15	159805001	1	イトチヨウシサラオサエ	DISC PRESSER, ;TENSION	
16	145446001	2	イトチヨウシサラ	DISC, TENSION	
17	100402004	1	トメネジ3.57	SET SCREW, SM3.57	
18	S10469001	1	アナトメネジ5.95	SET SCREW, SOCKET SM5.95	
19	115186001	1	シユイトチヨウシボウ	TENSION STUD, ;MAIN	
20	100136001	1	イトチヨウシナツト	NUT, TENSION	
21	115188001	1	シユイトチヨウシバネ	SPRING, TENSION	
22	145446001	2	イトチヨウシサラ	DISC, TENSION	
23	152889001	1	ミツメイトカケ	THREAD RETAINER	
24	062670612	2	ナベコ357-40X6	SCREW, PAN SM3.57-40X6	
25-2	S41222101	1	<中厚物用> ハリボウイトアンナイB	<For Medium-weight materials> THREAD GUIDE, B ;N-BAR	
25-3	S02438001	1	<厚物用> ハリボウイトアンナイA	<For Heavy-weight materials> THREAD GUIDE, A ;N-BAR	
26	152891101	1	ハリボウメタルDイトアンナイ	THREAD GUIDE, ;N-BAR BUSH	
33	S12441001	1	チヨウシバネウエザガネ	WASHER	
25-4	S02439001	1	" オフション部品 " <極厚物用> ハリボウイトアンナイB	" OPTION PARTS " <For Extra heavy-weight materials> THREAD GUIDE, B ;N-BAR	
27	152881001	1	エクレイタイクミ	NEEDLE COOLER ASSY	
28	014760632	1	アナクボミ595-28X6	SET SCREW, SOCKET (CP)SM5.95X6	
29	152883000	1	フェルト8X15.5	FELT, 8X15.5	
30	152884001	1	エクレイイトカケ	THREAD GUIDE, ;N-COOLER	
31	062670412	1	ナベコ357-40X4	SCREW, PAN SM3.57-40X4	

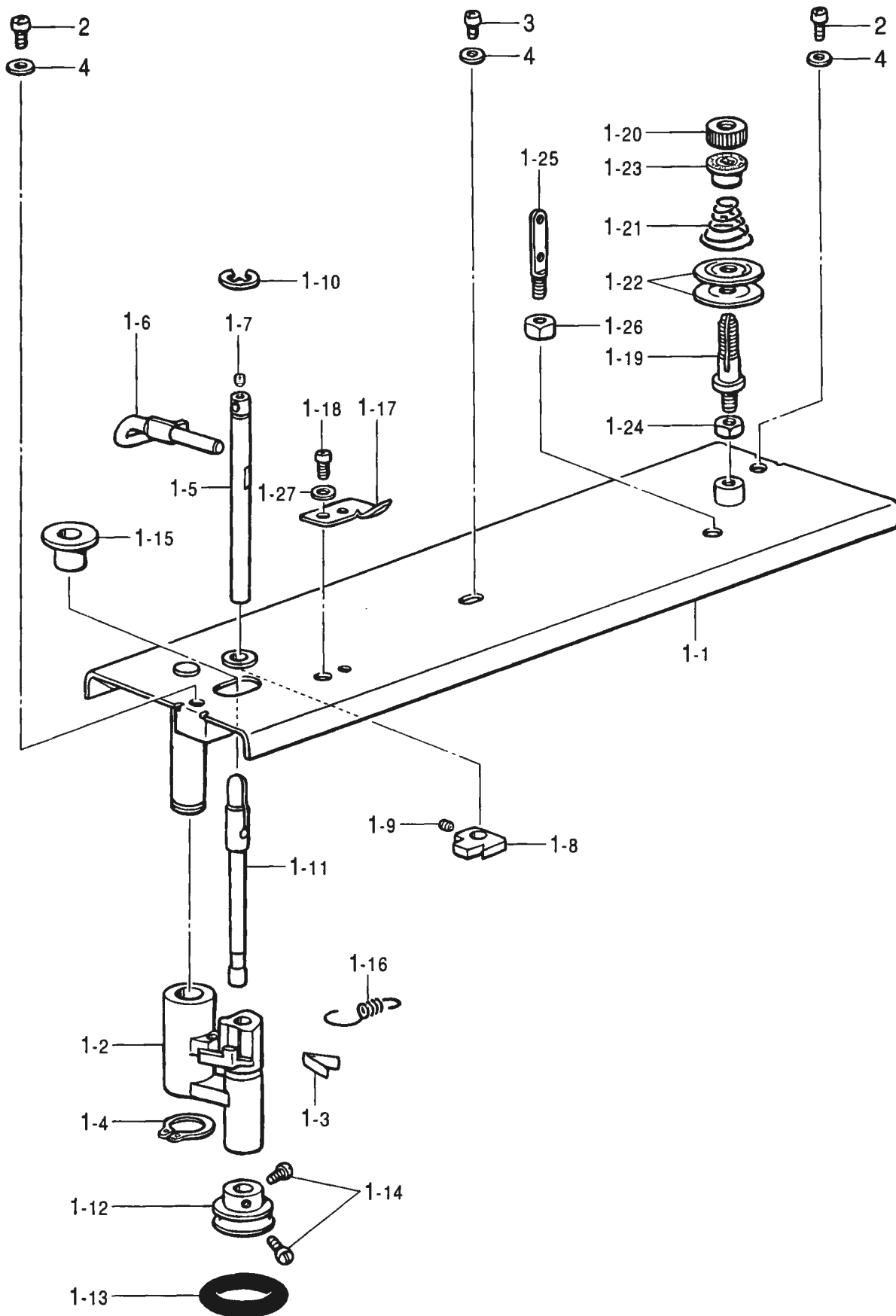

H. 糸巻関係 / Bobbin winder mechanism

REF.NO.	CODE	Q'TY	ヒンメイ	NAME OF PARTS	RM
1	S37990509	1	ウフフタクミ	TOP COVER ASSY	
1-1	S37991109	1	ウフフタ	TOP COVER	
1-2	S37992100	1	イトマキウテ	BOBBIN WINDER ARM	
1-3	S37993000	1	イタバネ	SPRING, PLATE	
1-4	048100142	1	トメワシクヨウC10	RETAINING RING, EXTERNAL C10	
1-5	S37994001	1	イトマキツメシク	STUD, ;B-WINDER CLAW	
1-6	S37995101	1	ホヒンオサエ	BOBBIN PRESSER	
1-7	013679412	1	トメネシ3.57クホミ	SET SCREW, (CP) SM3.57	
1-8	S37996001	1	イトマキツメ	CLAW, ;B-WINDER	
1-9	014680622	1	アナトメネシ4.37クホミ	SET SCREW, SOCKET (CP) SM4.37	
1-10	048050342	1	トメワE5	RETAINING RING, E5	
1-11	S37997001	1	イトマキシク	SHAFT, ;B-WINDER	
1-12	154528001	1	イトマキクルマ	WHEEL, ;B-WINDER	
1-13	120448001	1	ゴムワ	RUBBER RING	
1-14	120990001	2	アタマツキトメネシ4.37	SET SCREW, (CP) SM4.37-40X8	
1-15	S10174000	1	ホコリヨケイタ	DUST GUARD PLATE	
1-16	S37998001	1	イトマキウテハネ	SPRING	
1-17	157968001	1	メス	KNIFE	
1-18	062680512	1	ナヘコ437-40X5	SCREW, PAN SM4.37-40X5	
1-19	159574101	1	イトチヨウシホウ	TENSION STUD	
1-20	100136001	1	イトチヨウシナツト	NUT, TENSION	
1-21	144110001	1	シタルーハイトチヨウシハネ	TENSION ADJUSTING SPRING	
1-22	145446001	2	イトチヨウシサラ	DISC, TENSION	
1-23	144105000	1	チヨウシハネウエザカネ	FLANGE WASHER, ;T-SPRING	
1-24	021680202	1	ナツト2シユ4.37	NUT, 2 SM4.37	
1-25	141590001	1	イトトオシホウ	THREADING BAR, U	
1-26	100022004	2	ナツト5.95	NUT, SM5.95	
1-27	025680232	1	ヒラザガネチユウ4.37	WASHER, PLAIN M 4.37	
2	062681212	2	ナベコ437-40X12	SCREW, PAN SM4.37-40X12	
3	062680612	1	ナベコ4.37-40X6	SCREW, PAN SM4.37-40X6	
4	025680232	3	ヒラザガネチユウ4.37	WASHER, PLAIN M 4.37	

J. 糸切り関係 / Thread trimmer mechanism

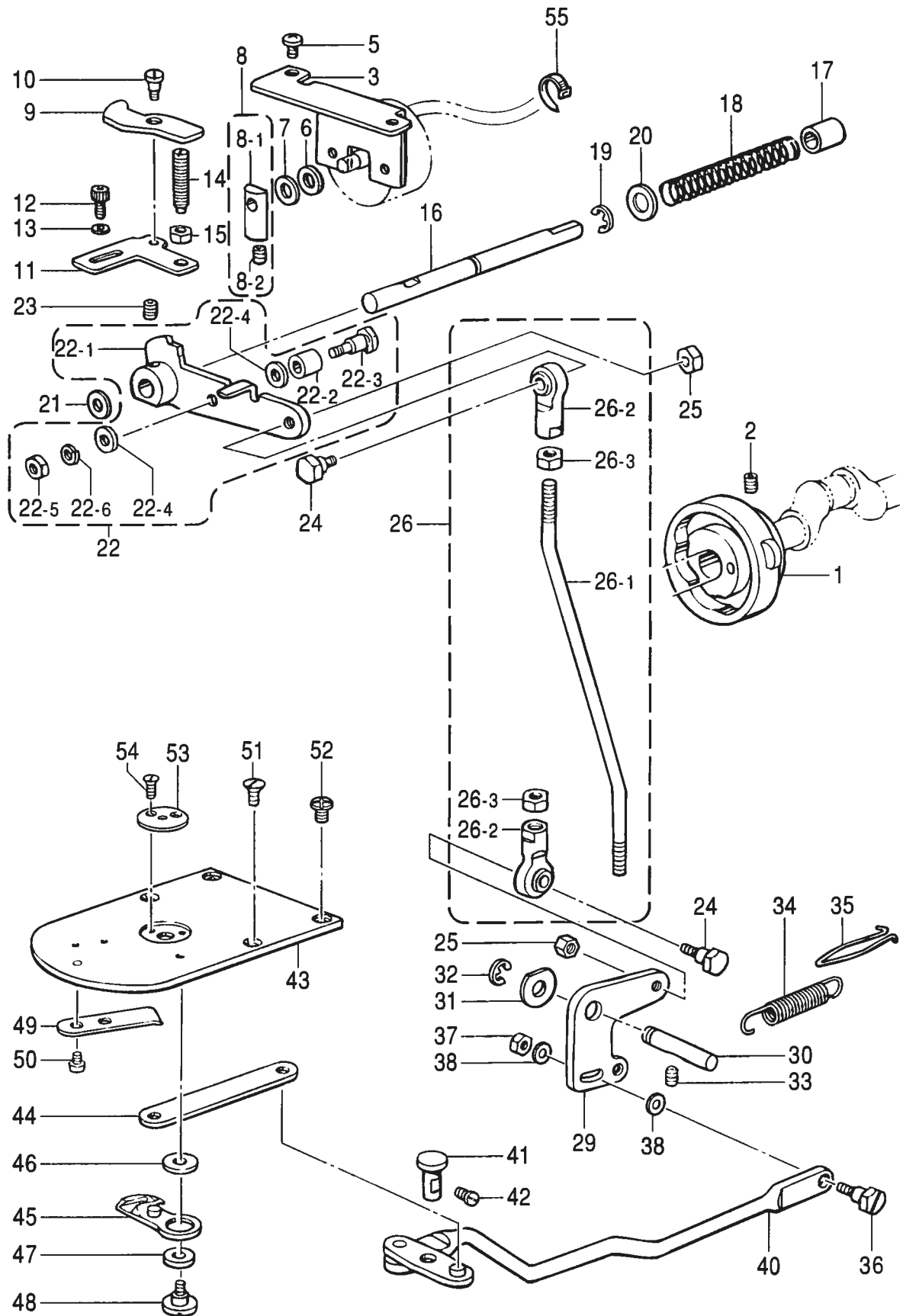

J. 糸切り関係 / Thread trimmer mechanism

REF.NO.	CODE	Q'TY	ヒンメイ	NAME OF PARTS	RM
1	S49629101	1	イトキリカム	THREAD TRIMMER CAM	
2	014770622	2	アナトメネジ6.35クボミ	SET SCREW, SOCKET (CP) SM6.35	
3	S38002201	1	ソレノイドトリツケイタ	SETTING PLATE, ;SOLENOID	
5	060681212	2	バインド437-40X12	SCREW, BIND SM4.37-40X12	
6	154599000	1	ソレノイドクツシヨン	CUSHION, ;SOLENOID	
7	S02652001	1	ザガネ	WASHER	
8	S23836001	1	ソレノイドレバークミ	SOLENOID LEVER ASSY	
8-1	S02654001	1	ソレノイドレバー	SOLENOID LEVER	
8-2	014680622	1	アナトメネシ4.37クホミ	SET SCREW, SOCKET (CP) SM4.37	
9	S38003101	1	クトウレバーオシレバー	PUSHING LEVER, ;D-LEVER	
10	S49645001	1	ダンネジ4.76	SHOULDER SCREW, SM4.76	
11	S38004002	1	クドウレバーストツハ <記号2>	DRIVING LEVER STOPPER, H = 0.3 <Marked in 2>	
11	S38004003	1	クドウレバーストツハ <記号3>	DRIVING LEVER STOPPER, H = 0.6 <Marked in 3>	
11	S38004004	1	クドウレバーストツハ <記号4>	DRIVING LEVER STOPPER, H = 0.45 <Marked in 4>	
12	018681022	2	アナホルト4.37X10	BOLT, SOCKET SM4.37X10	
13	148847001	2	サカネ	WASHER, PLAIN 4.76	
14	159905001	1	トメヌイチヨウセツネシ	ADJUSTING SCREW	
15	105812003	1	ナツト7.94	NUT, SM7.94	
16	S49644001	1	クトウレバーアンナイシク	GUIDE SHAFT	
17	231071001	1	メタル8X15	BUSH, 8X15	
18	S32235001	1	ヌノオサエハネ	SPRING, COMPRESSION	
19	048070342	1	トメワE7	RETAINING RING, E7	
20	153596001	1	ザガネ	WASHER	
21	154596000	1	イトキリカムレバークツシヨン	CUSHION	
22	S49646001	1	イトキリクドウレバークミ	TR-DRIVING LEVER ASSY	
22-1	S49647001	1	イトキリクドウレバー	TR-DRIVING LEVER	
22-2	153597001	1	シタイトサバキカラー	RETAINER COLLAR, ;L-THREAD	
22-3	S30033001	1	ダンネジ3.57	SHOULDER SCREW, SM3.57	
22-4	148813001	2	ザガネ	WASHER	
22-5	106129001	1	ナツト3.57	NUT, SM3.57	
22-6	028350242	1	バネザガネ2-3.5	WASHER, SPRING 2-3.5	
23	014770622	1	アナトメネジ6.35クボミ	SET SCREW, SOCKET (CP) SM6.35	
24	S02354001	2	タマツギテダンネジB	SHOULDER SCREW, B	
25	100022005	2	ナツト5.95	NUT, SM5.95	
26	S49648001	1	イトキリロツドクミ	THREAD TRIMMER ROD ASSY	
26-1	S49649001	1	イトキリロツト	THREAD TRIMMER ROD	
26-2	141492001	2	タマツギテクミ	JOINT ASSY	
26-3	100022005	2	ナツト5.95	NUT, SM5.95	
29	S49650001	1	イトキリレバー	THREAD TRIMMER LEVER	
30	S10195001	1	イトキリレバーシク	SHAFT, ;TR-TRIMMER LEVER	
31	110367001	1	ザガネ	WASHER, PLAIN SPECIAL 8	
32	048060342	1	トメワE6	RETAINING RING, E6	
33	014760622	1	アナトメネシ5.95	SET SCREW, SOCKET SM5.95	
34	S38011001	1	イトキリモトシバネ	SPRING, EXTENSION	
35	S49651001	1	バネカケ	SPRING HOOK	
36	110233001	1	ダンネジ4.76	SHOULDER SCREW, SM4.76	
37	110161004	1	ナツト4.76	NUT, SM4.76	
38	S49994001	2	ザガネ4.76	WASHER, PLAIN 4.76	
40	S38012001	1	レンカンレバークミ	CONNECTING ROD LEVER ASSY	
41	S10202101	1	レンカンレバークミ	LEVER SHAFT	
42	121007001	1	アタマツキトメネジ4.37	SET SCREW, SM4.37	
43	S38015001	1	ハリイタ	NEEDLE PLATE	
44	S38016001	1	イトキリレンカン	CONNECTING ROD, ;TR	
45	S49988001	1	イドウハクミ	MOVABLE KNIFE ASSY, N	
46	S10208001	1	イドウハカンザ <t=0.4>	SPACER, MOVABLE KNIFE T = 0.4 .. <t=0.4>	
46	S10208002	1	イドウハカンザ <t=0.5>	SPACER, MOVABLE KNIFE T = 0.5 .. <t=0.5>	
46	S10208003	1	イドウハカンザ <t=0.6>	SPACER, MOVABLE KNIFE T = 0.6 .. <t=0.6>	
47	S00705001	1	イドウハカラー	COLLAR, ;M-KNIFE	
48	S10209101	1	シメネジ4.37	SCREW, SM4.37	

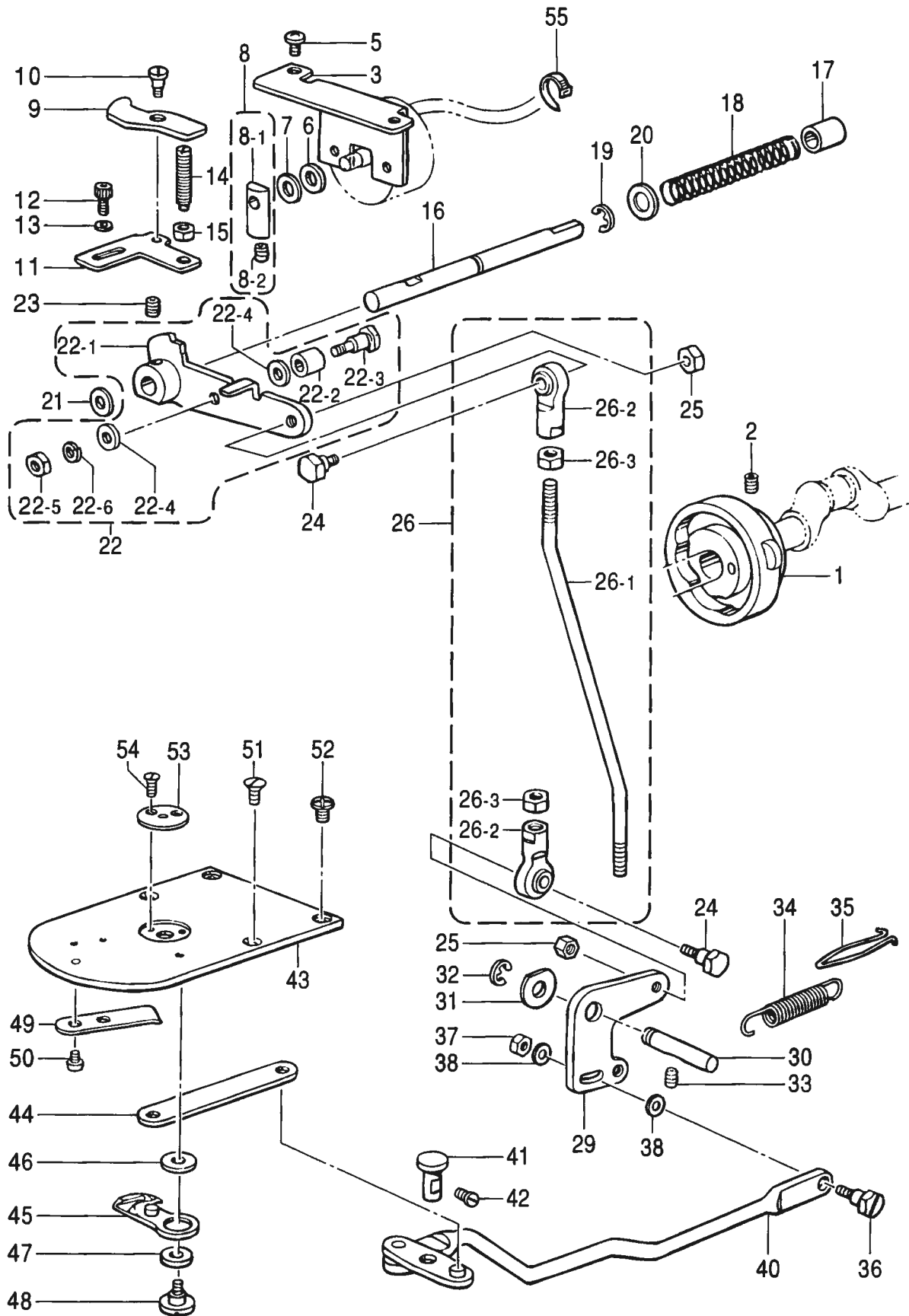

J. 糸切り関係 / Thread trimmer mechanism

REF.NO.	CODE	Q'TY	ヒンメイ	NAME OF PARTS	RM
49	S10210201	1	コテイハ	FIXED KNIFE	
50	111140002	2	シメネシ2.38	SCREW, SM2.38	
51	100032004	2	サラネシ4.37	SCREW, FLAT SM4.37-40X8	
52	S11244001	2	シメネシ4.37	SCREW, SM4.37	
53	*	1	ハリアナイタ	NEEDLE HOLE PLATE	
54	100360003	2	サラネシ2.38	SCREW, FLAT SM2.38	
55	228475000	1	ケツソクバンド1.9X80	FASTENING BAND, 1.9X80	

K. 糸払イ関係 / Thread wiper mechanism

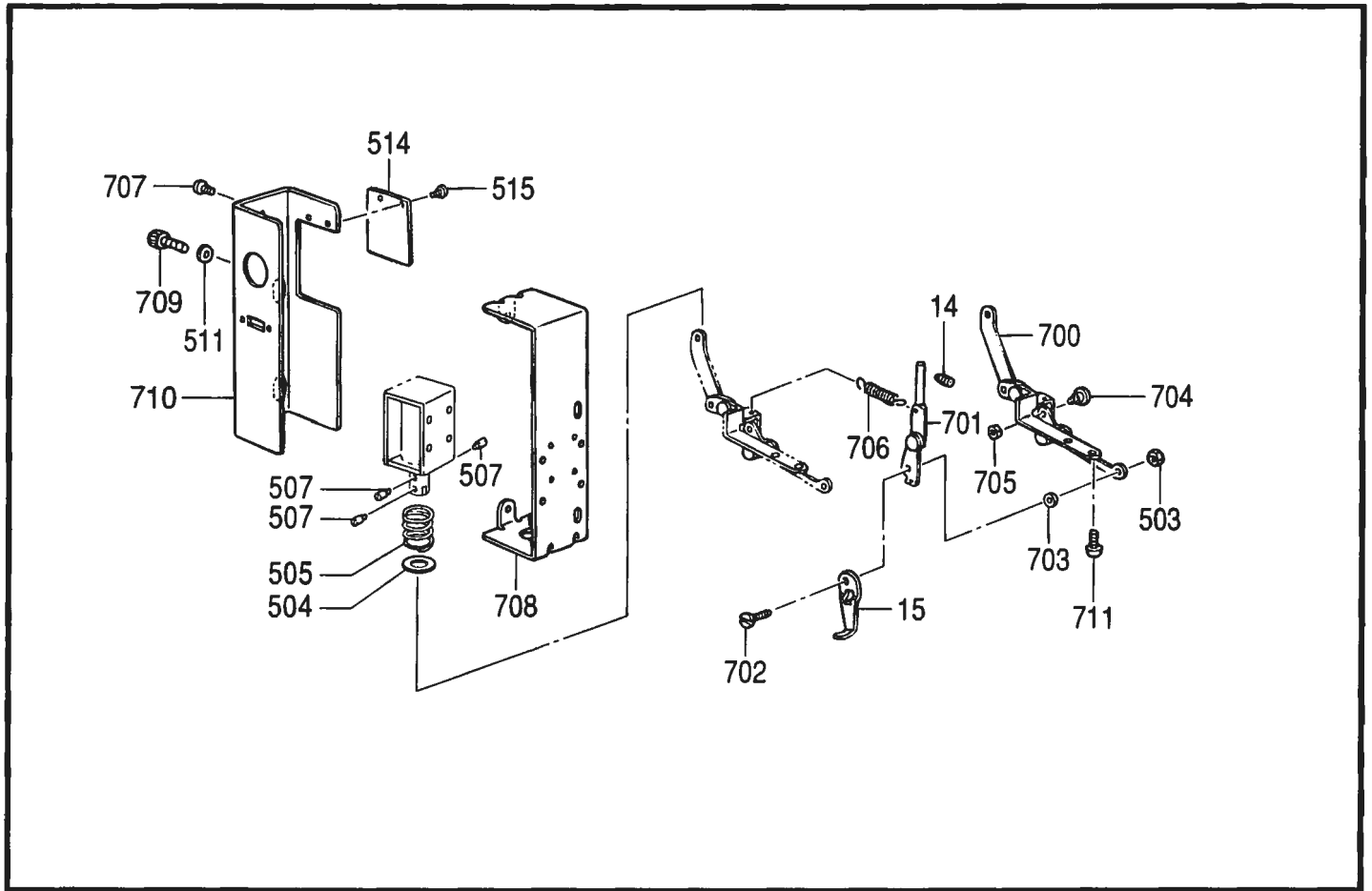

118-P34-405

L. 糸取り関係 / Thread take-up mechanism

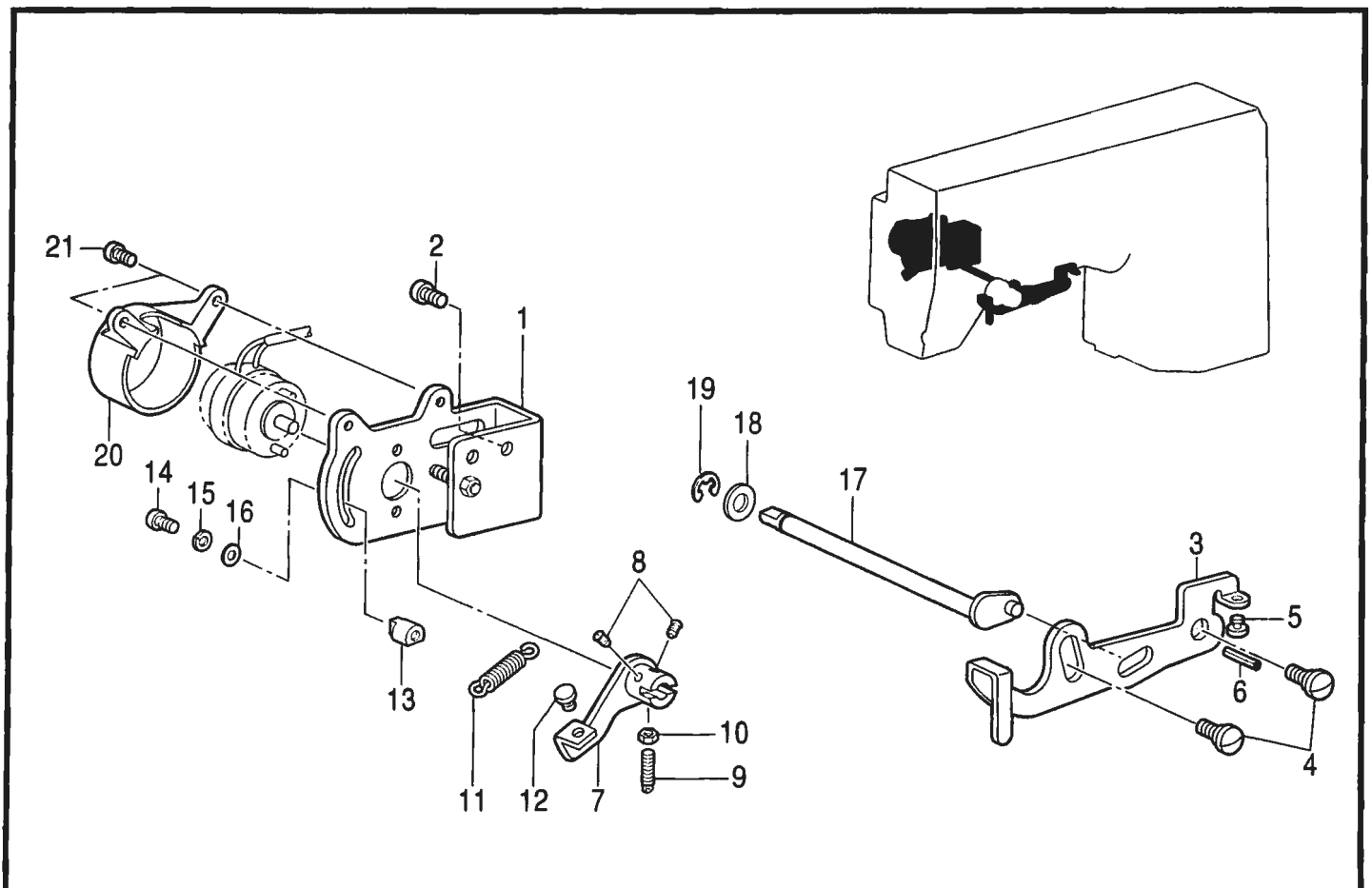

118-P34-408

K. 糸払イ関係 / Thread wiper mechanism

REF.NO.	CODE	Q'TY	ヒンメイ	NAME OF PARTS	RM
14	014710522	1	アサトメネシ4.76クホミ	SET SCREW, SOCKET (CP) SM4.76	
15	156206001	1	ワイハーA	THREAD WIPER, A	
503	021670202	1	ナツト2シユ3.57	NUT, 2 SM3.57	
504	S41205001	1	ヒラザガネ	WASHER, PLAIN	
505	S41206001	1	イトハライバネ	SPRING, ;T-WIPER	
507	S25456001	3	フランシヤヒン	PLUNGER PIN	
511	100645003	2	ザカネ	WASHER	
514	S37806109	1	ソレノイトカバーEフタ	SOLENOID COVER LID, E	
515	008400604	2	+トラスコ4X6	SCREW, TRUSS M4X6	
700	S42859001	1	イトハライレンカンヨコクミ	T-WIPER CONNECTING ROD ASSY	
701	S42864101	1	ワイハーウテクミ	WIPER ARM ASSY	
702	S13385001	1	シメネシ3.57X10	SCREW, SM3.57-40X10	
703	S12668001	1	カラー	COLLAR	
704	100659001	1	ダンネシ3.18	SHOULDER SCREW, SM3.18	
705	021660102	1	ナツト1シユ3.18	NUT, 1 SM3.18	
706	159111001	1	Cクラツチアンナイバネ	SPRING, EXTENSION	
707	062680512	2	ナベコ437-40X5	SCREW, PAN SM4.37-40X5	
708	S37147109	1	ソレノイトトリツケイタE	SETTING PLATE, E ;SOLENOID	
709	018681022	2	アナホルト4.37X10	BOLT, SOCKET SM4.37X10	
710	S37148109	1	ソレノイトカバーE	SOLENOID COVER, E	
711	062680512	2	ナベコ437-40X5	SCREW, PAN SM4.37-40X5	

118-P34-405

L. 糸取り関係 / Thread take-up mechanism

REF.NO.	CODE	Q'TY	ヒンメイ	NAME OF PARTS	RM
1	S55181001	1	ソレノイドトリツケイタクミ	SETTING PLATE ASSY, SOL.	
2	062710812	2	ナベコ476-32X8	SCREW, PAN SM4.76-32X8	
3	S49660001	1	イトトリレバー	LEVER	
4	107321003	2	ダンネシ4.76	SHOULDER SCREW, SM4.76	
5	S19748001	1	サドウ克蘭ククツシヨン	CUSHION	
6	047401442	1	スフリングヒンAW4	PIN, SPRING ROLL AW4	
7	S49661001	1	ソレノイドツギテ	SOLENOID JOINT	
8	S01998001	2	アタマツキトメネシ3.57	SET SCREW, SM3.57-40X6	
9	110251001	1	ヌノオサエウデバネカケ	SPRING HOOK	
10	021670102	1	ナツト1シユ3.57	NUT, 1 SM3.57	
11	S34883001	1	イトキリバネ	SPRING, EXTENSION	
12	S19748001	1	サドウ克蘭ククツシヨン	CUSHION	
13	S49663001	1	ナツト3.57	NUT, SM3.57	
14	062671012	1	ナベコ357-40X10	SCREW, PAN SM3.57-40X10	
15	028350242	1	バネザガネ2-3.5	WASHER, SPRING 2-3.5	
16	025350332	1	ヒラザガネダイ3.5	WASHER, PLAIN L 3.5	
17	S55111001	1	イトトリレバークランク	CRANK, ;T/TAKE-UP LEVER	
18	155559001	1	ヒラザガネ	WASHER, PLAIN	
19	048040342	1	トメワE4	RETAINING RING, E4	
20	S49664000	1	イトトリソレノイドカバー	COVER, ;T/TAKE-UP SOLENOID	
21	062670612	2	ナベコ357-40X6	SCREW, PAN SM3.57-40X6	

118-P34-408

M. 糸締メ関係 / Thread nipper mechanism

REF.NO.	CODE	Q'TY	ヒンメイ	NAME OF PARTS	RM
1	S55108001	1	イトユルメロツトクミ	TENSION RELEASE ROD ASSY, ;SF	
1-1	S55109001	1	イトユルメロツト	TENSION RELEASE ROD	
1-2	141492001	1	タマツギテクミ	JOINT ASSY	
1-3	100022005	1	ナツト5.95	NUT, SM5.95	
2	145478101	1	ダンネシ4.76	SHOULDER SCREW, SOCKET SM4.76	
3	S02354001	1	タマツギテダンネシB	SHOULDER SCREW, B	
4	100022005	1	ナツト5.95	NUT, SM5.95	
5	S49653001	1	イトユルメクドウレバークミ	T-RELEASE DRIVING LEVER ASSY	
5-1	S49654001	1	イトユルメクドウレバー	TENSION RELEASE DRIVING LEVER	
5-2	153597001	1	シタイトサバキカラー	RETAINER COLLAR, ;L-THREAD	
5-3	S30033001	1	ダンネジ3.57	SHOULDER SCREW, SM3.57	
5-4	S49655001	1	カラー	COLLAR	
5-5	106129002	1	ナツト3.57	NUT, SM3.57	
5-6	028350242	1	バネザガネ2-3.5	WASHER, SPRING 2-3.5	
6	S49656001	1	イトユルメレバーU	TENSION RELEASE LEVER, U	
7	S49657001	1	ユルメレバーUストツハ	STOPPER, U	
8	S19748001	1	サドウ克蘭クツシヨン	CUSHION	
9	062680812	2	ナベコ437-40X8	SCREW, PAN SM4.37-40X8	
15	048040342	2	トメワE4	RETAINING RING, E4	
16	109763002	1	ザガネ	WASHER	
22	S55199001	1	イトユルメヒンL	TENSION RELEASE PIN, L	
700	S42870201	1	イトユルメブラケット	TENSION RELEASE BRACKET	
701	062771012	1	ナベコ635-40X10	SCREW, PAN SM6.35-40X10	
702	S42873101	1	イトユルメレバー	LEVER, ;T-RELEASE	
703	S42871201	1	オサエアジアゲレバークミ	WORK CLAMP LIFTER LEVEER ASSY	
704	S55134001	1	オサエレバーバネ	SPRING	
705	S43900001	1	カンケツリンクA	STEPPING LINK, A	
706	025750132	1	ヒラザガネシヨウ5.56	WASHER, PLAIN S 5.56	
707	048040342	1	トメワE4	RETAINING RING, E4	
708	S43901001	1	カンケツリンクB	STEPPING LINK, B	
709	151907001	2	ダンネジ5.95	STUD SCREW 5.95	
710	100022005	2	ナツト5.95	NUT, SM5.95	
711	S43902001	1	カンケツリンクC	STEPPING LINK, C	
712	018681022	2	アナボルト4.37X10	BOLT, SOCKET SM4.37X10	
713	028680242	2	バネザガネ2-4.37	WASHER, SPRING 2-4.37	
714	100645003	2	ザガネ	WASHER	
715	S43909001	1	カンケツリンクベース	STEPPING LINK BASE	
716	159905001	1	トメヌイチヨウセツネジ	ADJUSTING SCREW	
717	106147002	1	ナツト7.94	NUT, SM7.94	
718	S43903001	1	シリンダツギテ	CYLINDER JOINT	
719	148764001	1	ダンネジ4.76	SHOULDER SCREW, SM4.76	
720	S10123001	1	オサエカムカラー	COLLAR	
721	110161004	2	ナツト4.76	NUT, SM4.76	
722	S46144100	1	シリンダ25X15クミ	CYLINDER ASSY, 25X15	
722-1	S46145000	1	シリンダ25X15	CYLINDER, 25X15	
722-2	S04905000	2	ハーフユニオン	HALF UNION	
723	S43904101	1	エアシリンダトリツケイタ	SETTING PLATE, AIR CYLINDER	
724	S24729000	4	CQ2ボルトM5X45	BOLT, CQ2 M5X45	
725	060681212	4	バインド437-40X12	SCREW, BIND SM4.37-40X12	

N. 針位置検出器関係 / Synchronizer

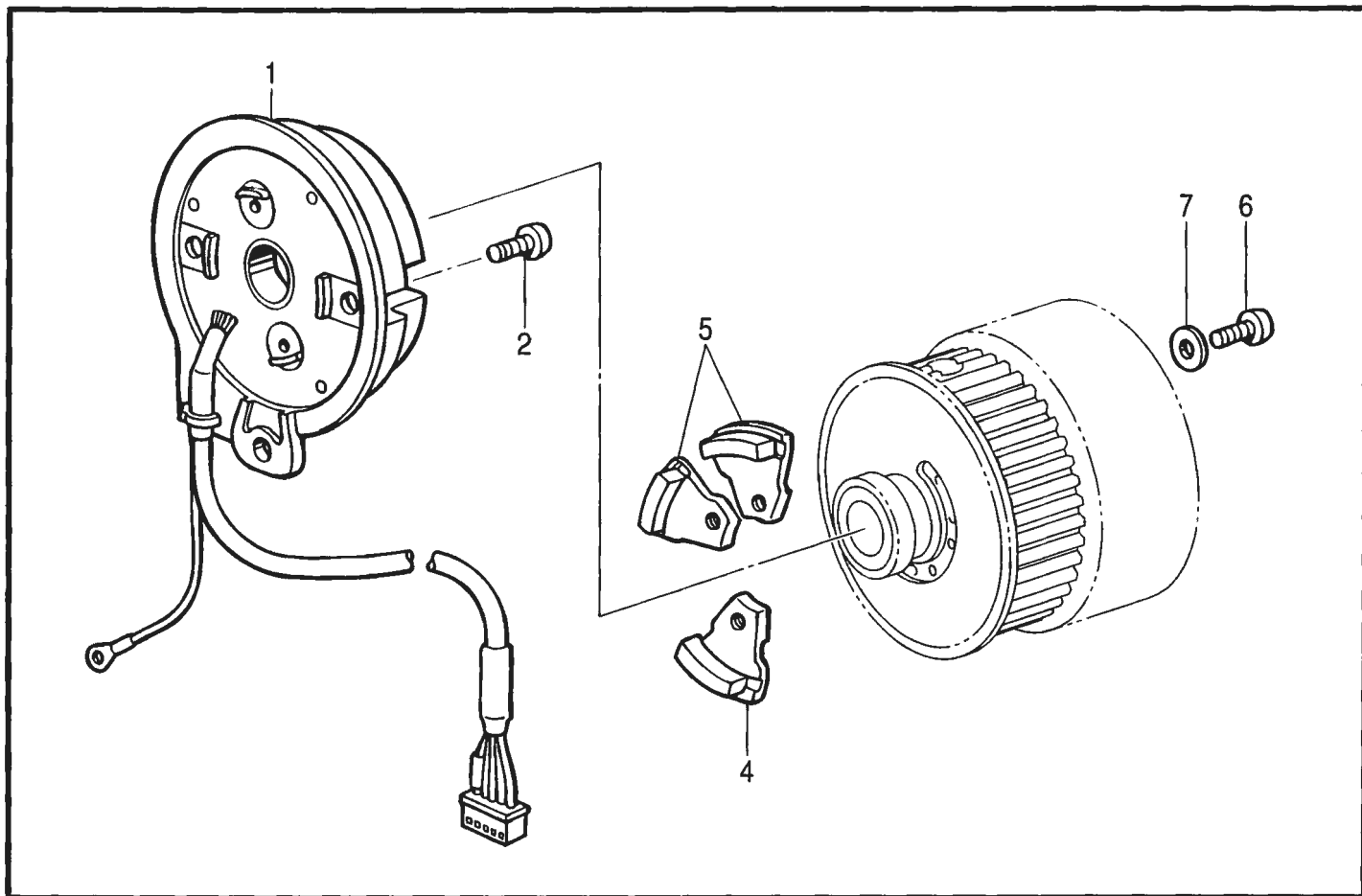

118-P34-501

P. プリント基板関係 / Printed circuit board mechanism

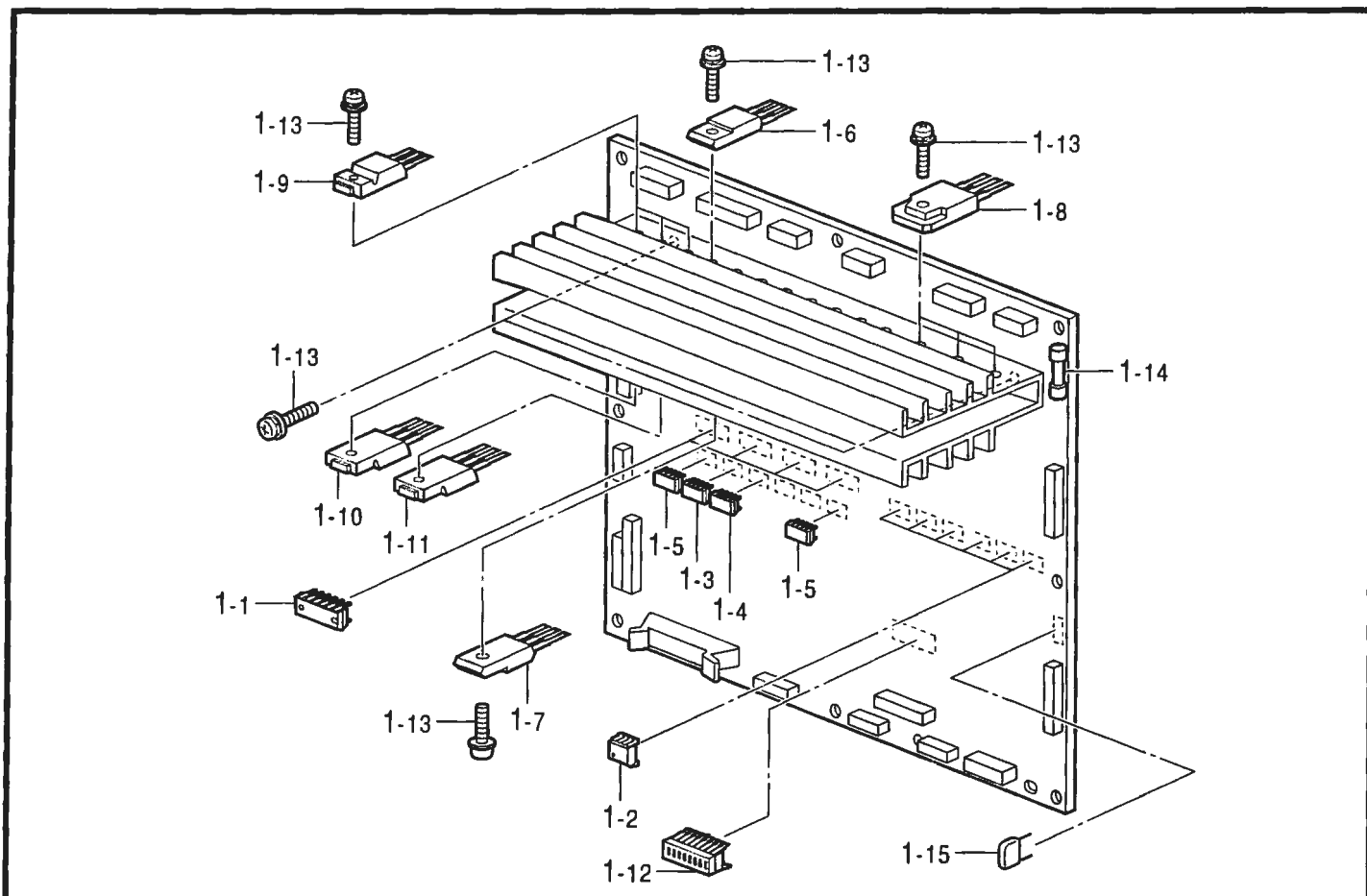

118-P34-518

N. 針位置検出器関係 / Synchronizer / Synchronisator

REF.NO.	CODE	Q'TY	ヒンメイ	NAME OF PARTS	RM
1	S48666001	1	シンクロナイザクミ	SYNCHRONIZER ASSY	
2	062400806	2	ナヘコ4X8	SCREW, PAN M4X8	
4	S38080001	1	ハリシタシシヤククミ	MAGNET ASSY, D	
5	S38082001	2	ハリウエシシヤククミ	MAGNET ASSY, U	
6	062681412	3	ナヘコ437-40X14	SCREW, PAN SM4.37-40X14	
7	025680132	3	ヒラザカネシヨウ4.37	WASHER, PLAIN S 4.37	

118-P34-501

P. プリント基板関係 / Printed circuit board mechanism

REF.NO.	CODE	Q'TY	ヒンメイ	NAME OF PARTS	RM
1	S49479001	1	メインキバンクミ	MAIN PCB ASSY	
1-1	S29019000	4	ICM54640P	IC:M54640P	
1-2	S43178000	6	PHカフラPC9231	PHOTO COUPLER, :PC9231	
1-3	093650008	1	CMOSIC74HC08F	IC :74HC08F	
1-4	093650032	1	CMOSIC74HC32F	IC :74HC32F	
1-5	091170009	2	BIPIC74LS09F	IC:74LS09F-T	
1-6	S49484000	8	MOSFETFS10KMJ-2	TRANSISTOR, FET :FS10KMJ-2	
1-7	S49485000	8	MOSFETFX6KMJ-2	TRANSISTOR, FET :FX6KMJ-2	
1-8	S49471000	6	MOSFETFK18SM-12	TRANSISTOR, FET :FK18SM-12	
1-9	S38155000	3	MOSFET2SK1306	TRANSISTOR, FET :2SK1306	
1-10	S50645000	1	MOSFET2SK1307	TRANSISTOR, FET :2SK1307	
1-11	S49486000	1	MOSFET2SJ222	TRANSISTOR, FET :2SJ222	
1-12	U32744000	1	DIPSWDSS708	DIP SWITCH:DSS708	
1-13	0A4301005	31	+ナベザクミ3X10DA	SCREW, PAN (S/P WASHER) M3X10	
1-14	S48578000	1	GFUSE5AFBリードツキ	GLASS FUSE, 5A ;W/LEED WIRE	
1-15	Y51030150	1	ホリC50B103	CAPACITOR, POLYESTER 50B103	

118-P34-518

Q1 . コントロールボックス関係 / Control box mechanism

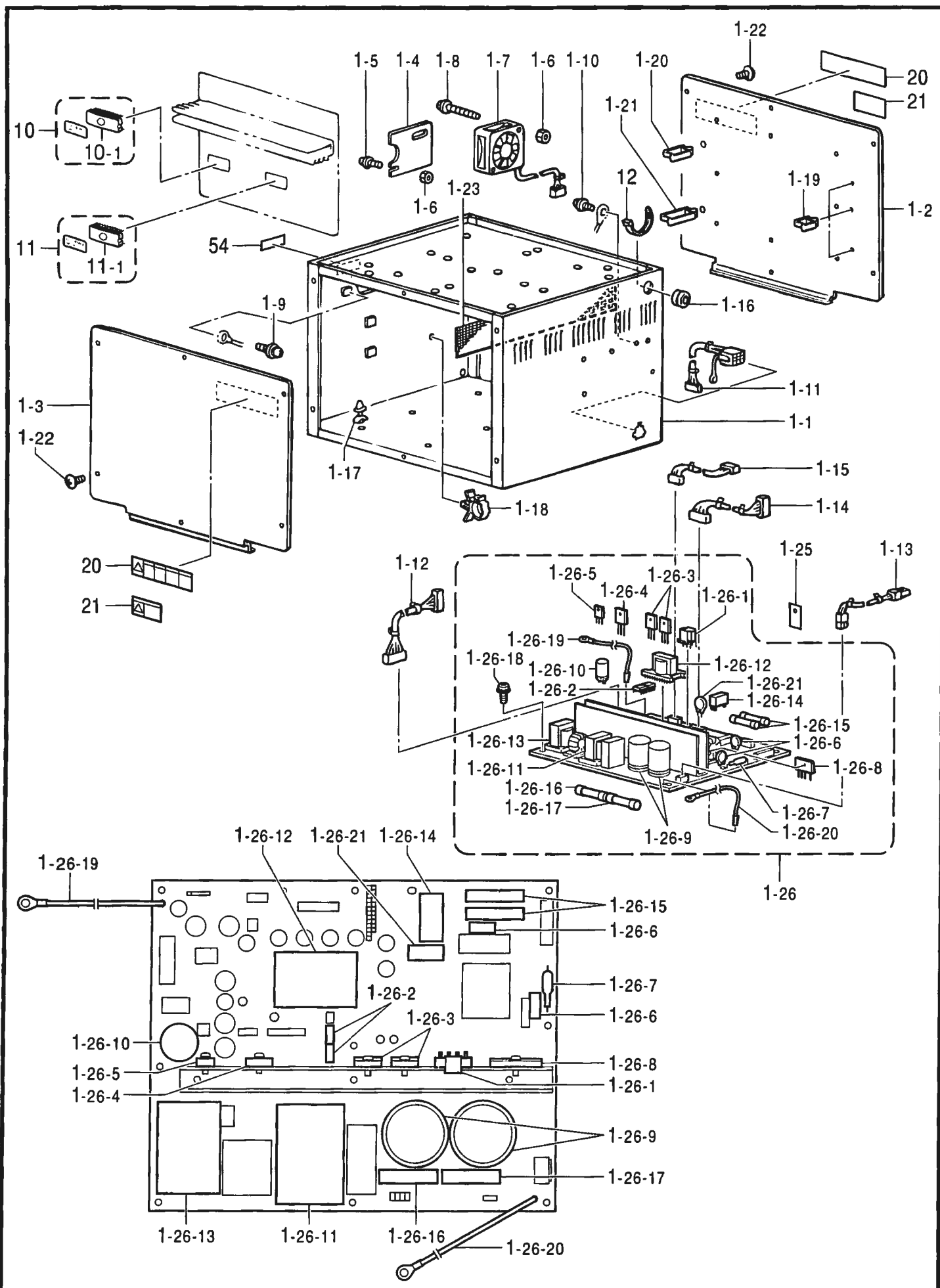

Q1. コントロールボックス関係 / Control box mechanism

REF.NO.	CODE	Q'TY	ヒンメイ	NAME OF PARTS	RM
1	S49467001	1	ボックスクミ	BOX ASSY	
1-1	S49468001	1	デンゲンボックス	POWER SUPPLY BOX	
1-2	S49469001	1	メインキバントリツケイタ	SETTING PLATE, ;MAIN PCB	
1-3	S49470001	1	ボックスフタ	BOX COVER	
1-4	S38093000	1	コードオサエイタ	HOLDER PLATE	
1-5	0A5401206	2	+ナヘザクミ 4X12DB	SCREW, PAN (S/P WASHER) M4X12	
1-6	021400206	2	2シユナツト4	NUT, 2 M4	
1-7	S47692000	1	DCファンモータクミ	FAN MOTOR ASSY, DC	
1-8	0A5403006	2	+ナベザクミ 4X30DB	SCREW, PAN (S/P WASHER) M4X30	
1-9	0A5400806	1	+ナベザクミ 4X8DB	SCREW, PAN (S/P WASHER) M4X8	
1-10	0A5401206	2	+ナベザクミ 4X12DB	SCREW, PAN (S/P WASHER) M4X12	
1-11	S42260000	1	フツトSWコード434クミ	FOOT SWITCH HARNESS ASSY, 434	
1-12	S38107100	1	セイギヨデンゲンコート	POWER SUPPLY HARNESS, CONTROL	
1-13	S38108000	1	モータデンゲンコード	POWER SUPPLY HARNESS, MOTOR	
1-14	S38109100	1	ゲートデンゲンコート	POWER SUPPLY HARNESS, H-P	
1-15	S38110000	1	PERコード	POWER HARNESS	
1-16	S11949000	1	ゴムブツシユ	RUBBER BUSH	
1-17	S00554000	17	サホート6NS	SUPPORT, 6NS	
1-18	S31760000	2	CKSクランプ26L	CORD CLAMP, 26-L	
1-19	S43275000	6	コードクランプWS2NS	CORD CLAMP, WS2NS	
1-20	S43276000	4	コードクランプWS3NS	CORD CLAMP, WS3NS	
1-21	S43277000	1	コードクランプWS4NS	CORD CLAMP, WS4NS	
1-22	008400604	12	+トラスコ4X6	SCREW, TRUSS M4X6	
1-23	S38116000	1	ボウジンアミ	FRAGMENT PROTECTOR NET	
1-25	S49938000	1	ゼツエンシート	INSULATION SHEET	
1-26	S49939001	1	デンゲンキバクミ	POWER SUPPLY PCB ASSY	
1-26-1	S43177000	1	ICMA3830	IC, :MA3830	
1-26-2	S43184000	2	PHカフラPC923	PHOTO COUPLER, ;PC923	
1-26-3	S49586000	2	MOSFET2SK1941	TRANSISTOR, FET ;2SK1941	
1-26-4	S55473000	1	SIDPA905C6-F	DIODE, AR :PA905C6-F	
1-26-5	S38203000	1	SBDYG802C04R	DIODE, :YG8022C04R	
1-26-6	S38201000	2	バリスタV14D471	VARIATOR, :V14D471	
1-26-7	232384001	1	SアブソバDSA362MA	SURGE ABSORBER, ;DSA362MA	
1-26-8	S49071000	1	DBRD25XB60	DIODE BRIDGE, :25XB60	
1-26-9	S38205000	1	デンC250B182	CAPACITOR, ALUM-ELEC :250B182	
1-26-10	S38206000	1	デンC63B272	CAPACITOR, ALUM-ELEC :63B272	
1-26-11	S43175000	1	トランスETS54AA159	TRANSFORMER, :54AA159	
1-26-12	S43176000	1	トランスETS35AD199	TRANSFORMER, :35AD199	
1-26-13	S43181000	1	コイルETS49AD289AC	COIL, :49AD289AC	
1-26-14	S38208000	1	RYJW1AFSND5V	RELAY, :JW1AFSN/DC 5V	
1-26-15	153242000	2	ヒユース6A	FUSE, 6A	
1-26-16	S08030000	1	Gヒユース5AFB	FUSE, 5A ;FB	
1-26-17	S48580000	1	GFUSE7AFB	FUSE, 7A ;FB	
1-26-18	0A4301005	8	+ナベザクミ 3X10DA	SCREW, PAN (S/P WASHER) M3X10	
1-26-19	S43189000	1	PCBE1コート	HARNESS, PCB ;E1	
1-26-20	S43187000	1	PCBE2コート	HARNESS, PCB ,E2	
1-26-21	S49472000	1	サーミスタ6D-22	THERMISTOR :6D-22	
10	S55404000	1	PROMセイギヨクミ	PROM ASSY, CONTROL	
10-1	UA4817000	1	MOSLSI27C2001	EPROM:27C2001	
11	S53032000	1	PROM-IMクミ	PROM ASSY, IM	
11-1	S38143000	1	CM0SLSI27C512	CMOS LSI, 27C512	
12	228475000	1	ケツツクバンド1.9X80	FASTENING BAND, 1.9X80	

118-P34-502

☆ RM欄に※が付いている部品をご注文頂きますと、基板等必要な部品が一式入ったセットになっております。

☆ When ordering parts which have an asterisk (*) in the RM column, these parts will be supplied as a set together with other necessary parts such as circuit boards.

Q1. コントロールボックス関係 / Control box mechanism

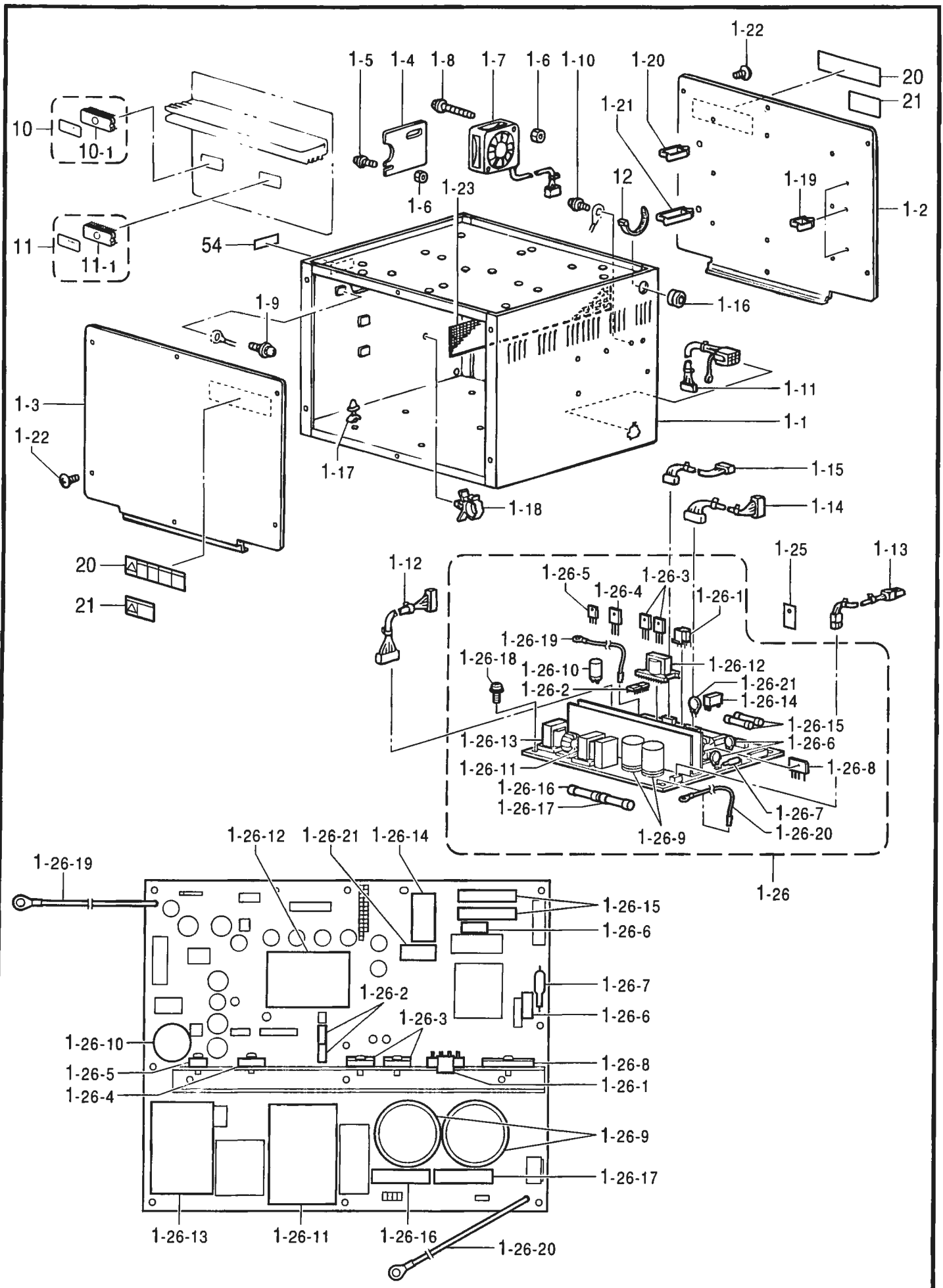

Q1. コントロールボックス関係 / Control box mechanism

REF.NO.	CODE	Q'TY	ヒンメイ	NAME OF PARTS	RM
20	S38352101	2	<輸出用> デンゲキラベル.4カコク	<For Export> LABEL, ELEC. SHOCK 4 LANG.	
21	S38353101	2	<国内用> デンゲキラヘルワ	<For Japan only> -----	
54	S55627001	1	IMラヘル	LABEL, IM	
H-1	S55414001	1	<三相200V,220V用> ホツクスソウクミA1-P	<For " 3-Phase 200V & 220V AC "> BOX SET, A1-P ;3-P. 200/220V	☆
H-2	S55415001	1	<单相220V,230V用> ホツクスソウクミA2-P	<For " 1-Phase 220V & 230V AC "> BOX SET, A2-P ;1-P. 220/230V	☆
H-3	S55416001	1	<单相100V用> ホツクスソウクミB1-P	<For Japan only> -----	☆
H-4	S55417001	1	<单相110V,120V用> ホツクスソウクミB2-P	<For " 1-Phase 110V & 120V AC "> BOX SET, B2-P ;1-P. 110V AC	☆
H-5	S55418001	1	<三相415V用> ホツクスソウクミC1-P	<For " 3-Phase 415V AC "> BOX SET, C1-P ;3-P. 415V AC	☆
H-6	S55419001	1	<三相380V用> ホツクスソウクミC2-P	<For " 3-Phase 380V AC "> BOX SET, C2-P ;3-P. 380V AC	☆
H-7	S55420001	1	<单相240V用> ホツクスソウクミC3-P	<For " 1-Phase 240V AC "> BOX SET, C3-P ;1-P. 240V AC	☆
H-8	S55421001	1	<三相400V用> ホツクスソウクミE-P	<For " 3-Phase 400V AC "> BOX SET, E-P ;3-P. 400V AC	☆
H-9	S55422001	1	<单相230V用> ホツクスソウクミF-P	<For " 1-Phase 230V AC "> BOX SET, F-P ;1-P. 230V AC	☆

118-P34-502

☆ RM欄に※が付いている部品をご注文頂きますと、基板等必要な部品が一式入ったセットになっております。

☆ When ordering parts which have an asterisk (☆) in the RM column, these parts will be supplied as a set together with other necessary parts such as circuit boards.

< 三相200V,220V用 / For "3-Phase 200V & 220V AC" >

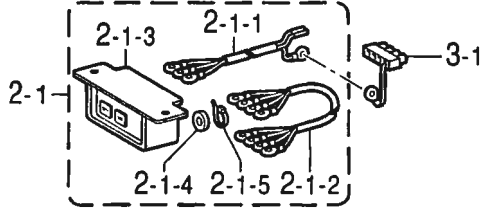

< 単相220V,230V用 / For "1-Phase 220V & 230V AC" >

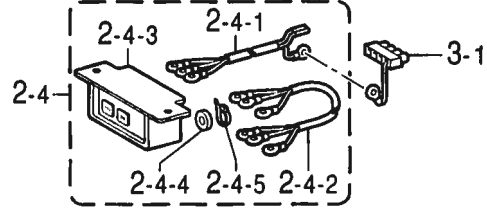

< 単相100V用 / For Japan only >

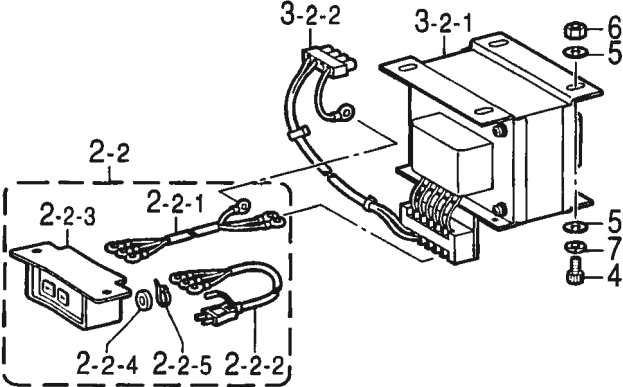

< 単相110V,120V用 / For "1-Phase 110V & 120V AC" >

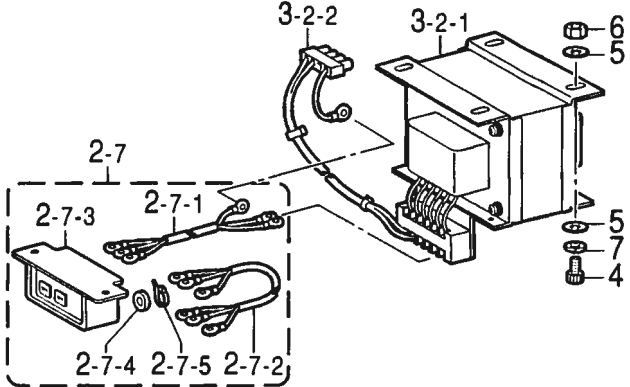

< 三相415V,380V用 / For "3-Phase 415V & 380V AC" >

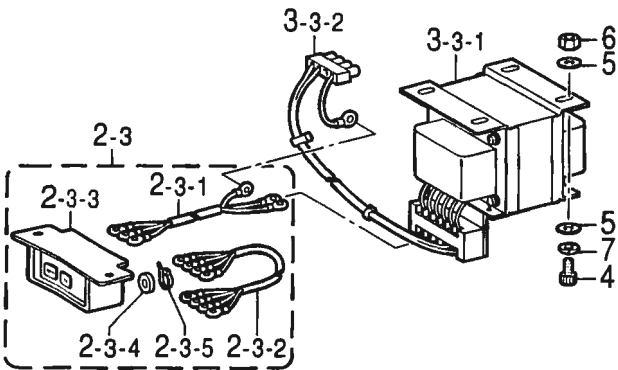

< 単相240V用 / For "1-Phase 240V AC" >

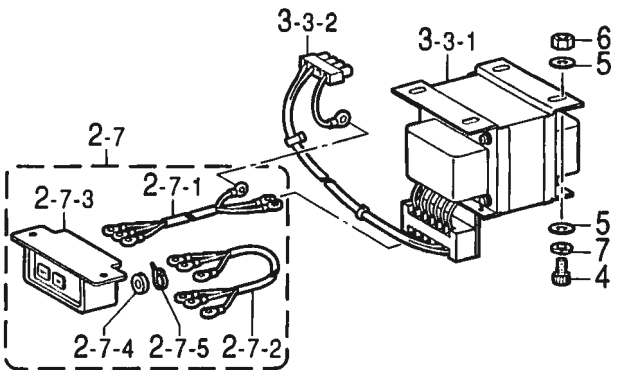

" オプション部品 / OPTION PARTS "

< 三相400V / For "3-Phase 400V AC" >

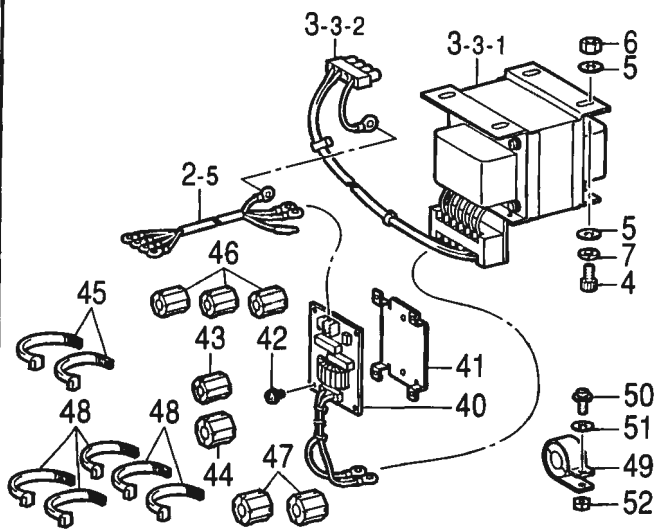

< 単相230V / For "1-Phase 230V AC" >

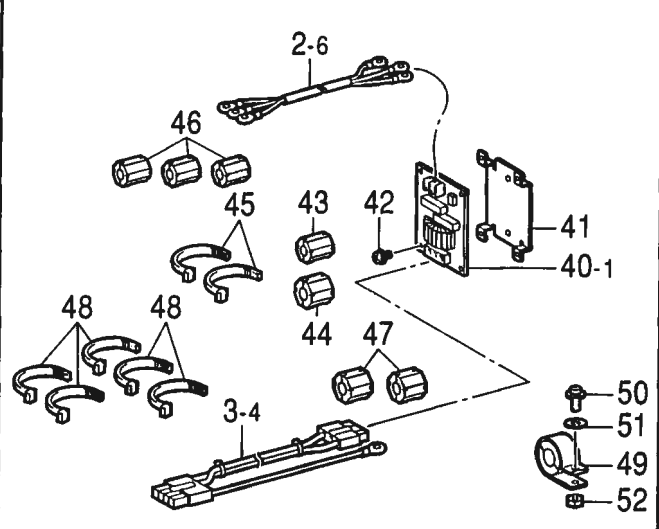

Q2. コントロールボックス関係 / Control box mechanism

REF.NO.	CODE	Q'TY	ヒンメイ	NAME OF PARTS	RM
2-1	S38112001	1	<三相200V,220V用> デンゲンSWクミA	<For " 3-Phase 200V & 220V AC "> P-SUPPLY SWITCH ASSY, A	
2-1-1	S38113000	1	デンゲンINコートA	POWER SUPPLY HARNESS, A ;IN	
2-1-2	S38133000	1	デンゲンコート	POWER SUPPLY HARNESS	
2-1-3	J02657001	1	3PオシSW#17	PUSH SWITCH, 3P #17	
2-1-4	224514001	2	ゼツエンイタ	INSULATION PLATE	
2-1-5	218859001	2	バインダM150	BINDER, M150	
2-2	S38114000	1	<単相100V用> デンゲンSWクミB	<For Japan only> -----	
2-2-1	S38115000	1	デンゲンINコートB	-----	
2-2-2	S38118000	1	デンゲンコートコクナイ	-----	
2-2-3	J02657001	1	3PオシSW#17	-----	
2-2-4	224514001	2	ゼツエンイタ	-----	
2-2-5	218859001	2	バインダM150	-----	
2-3	S38117000	1	<三相415V,380V用> デンゲンSWクミC	<For " 3-Phase 415V & 380V AC "> POWER SUPPLY SWITCH ASSY, C	
2-3-1	S38115000	1	デンゲンINコートB	POWER SUPPLY HARNESS, B ;IN	
2-3-2	S38133000	1	デンゲンコート	POWER SUPPLY HARNESS	
2-3-3	J02657001	1	3PオシSW#17	PUSH SWITCH, 3P #17	
2-3-4	224514001	2	ゼツエンイタ	INSULATION PLATE	
2-3-5	218859001	2	バインダM150	BINDER, M150	
2-4	S47592000	1	<単相220V,230V用> デンゲンSWクミD	<For " 1-Phase 220V & 230V AC "> P-SUPPLY SWITCH ASSY, D	
2-4-1	S38113000	1	デンゲンINコートA	POWER SUPPLY HARNESS, A ;IN	
2-4-2	S47595000	1	デンゲンコートユシユツ	POWER SUPPLY HARNESS, EXP.	
2-4-3	J02657001	1	3PオシSW#17	PUSH SWITCH, 3P #17	
2-4-4	224514001	2	ゼツエンイタ	INSULATION PLATE	
2-4-5	218859001	2	バインダM150	BINDER, M150	
2-7	S47594000	1	<単相110V,120V,240V用> デンゲンSWクミG	<For " 1-Phase 110V,120V & 240V AC "> P-SUPPLY SWITCH ASSY, G	
2-7-1	S38115000	1	デンゲンINコートB	POWER SUPPLY HARNESS, B ;IN	
2-7-2	S47595000	1	デンゲンコードユシユツ	POWER SUPPLY HARNESS, EXP.	
2-7-3	J02657001	1	3PオシSW#17	PUSH SWITCH, 3P #17	
2-7-4	224514001	2	ゼツエンイタ	INSULATION PLATE	
2-7-5	218859001	2	バインダM150	BINDER, M150	
3-1	S38123000	1	<単相220V,230V用 三相200V,220V用> ACINコネクタクミ	<For " 1-Phase 220V & 230V AC 3-Phase 200V & 220V AC "> AC CONNECTOR ASSY, IN	
3-2	S49473000	1	<単相100V,110V,120V用> ハンカントランスBクミ	<For " 1-Phase 100V,110V & 120V AC "> CONVERSION TRANSFORMER ASSY, B	
3-2-1	S49474000	1	ハンカントランスB	CONVERSION TRANSFORMER, B	
3-2-2	S38126000	1	ACINコード	AC HARNESS, IN	
3-3	S49475000	1	<単相240V, 三相400V,415V,380V用> ハンカントランスCクミ	<For " 1-Phase 240V AC 3-Phase 400V,415V & 380V AC "> CONVERSION TRANSFORMER ASSY, C	
3-3-1	S49476000	1	ハンカントランスC	CONVERSION TRANSFORMER, C	
3-3-2	S38126000	1	ACINコード	AC HARNESS, IN	

< 三相200V,220V用 / For "3-Phase 200V & 220V AC" >

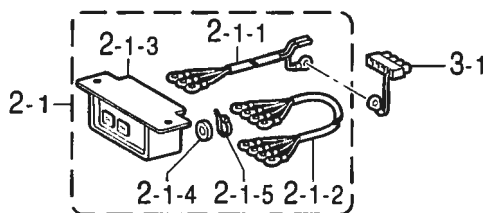

< 単相220V,230V用 / For "1-Phase 220V & 230V AC" >

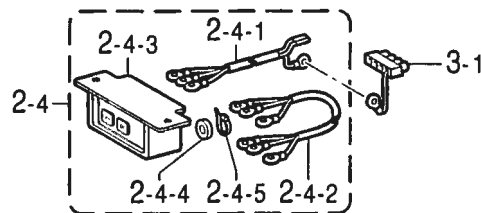

< 単相100V用 / For Japan only >

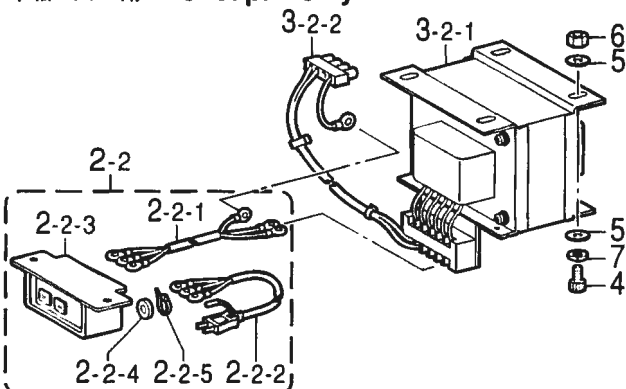

< 単相110V,120V用 / For "1-Phase 110V & 120V AC" >

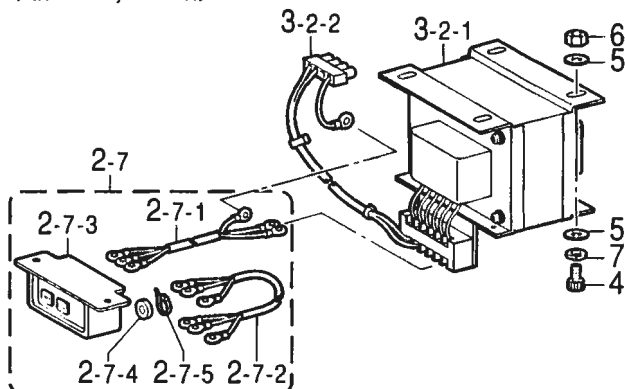

< 三相415V,380V用 / For "3-Phase 415V & 380V AC" >

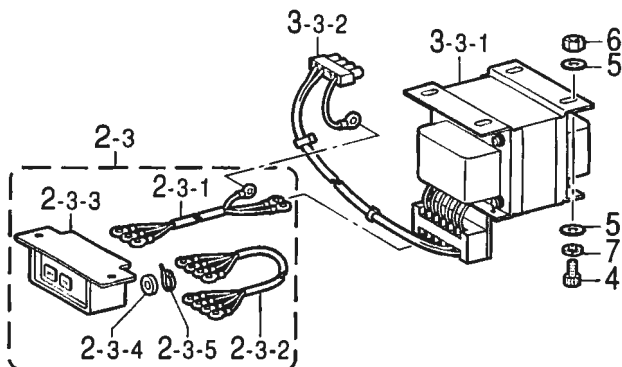

< 単相240V用 / For "1-Phase 240V AC" >

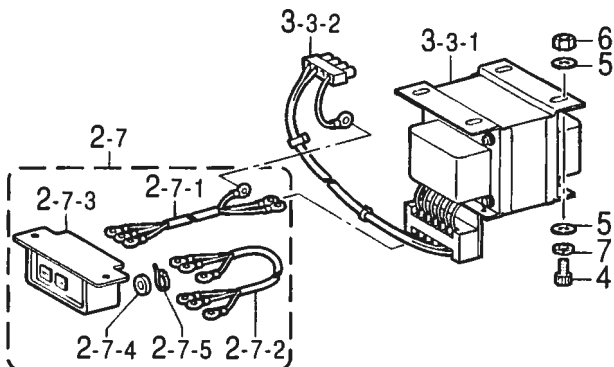

" オプション部品 / OPTION PARTS "

< 三相400V / For "3-Phase 400V AC" >

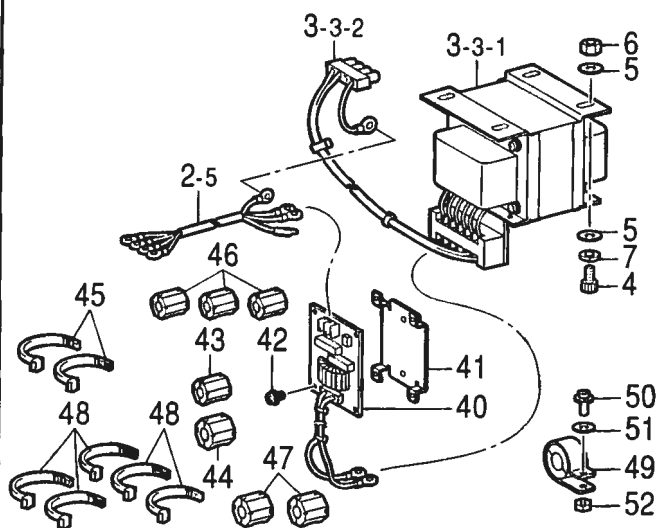

< 単相230V / For "1-Phase 230V AC" >

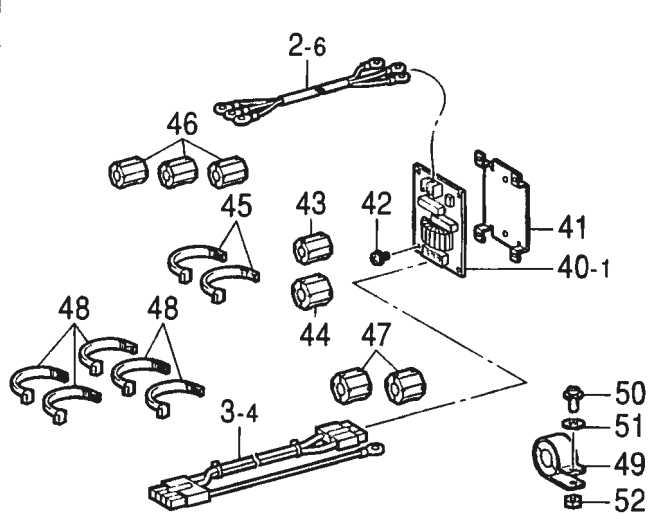

Q2. コントロールボックス関係 / Control box mechanism

REF.NO.	CODE	Q'TY	ヒンメイ	NAME OF PARTS	RM
4 5 6 7	018061436 025060236 021060106 028060246	4 8 4 4	<200V,220V,230V以外用> アナホルト6X14 ヒラザカネチユウ6 1シユナツト6 バネザカネ2-6	<Except for " 200V,220V & 230V AC "> BOLT, SOCKET M6X14 WASHER, PLAIN M 6 NUT, 1 M6 WASHER, SPRING 2-6	
2-5 40	S38120000 S40635001	1 1	" オプション部品 " <三相400V用> デンケンINコートE ノイズフィルタ430Eクミ	" OPTION PARTS " <For " 3-Phase 400V AC "> POWER SUPPLY HARNESS, E ;IN NOISE FILTER ASSY, 430E	
2-6 3-4 40-1	S43188000 S43201000 S40616001	1 1 1	<単相230V用> デンケンINコートF ACINコートF ノイズフィルタEMCクミ	<For " 1-Phase 230V AC "> POWER SUPPLY HARNESS, F ;IN AC HARNESS, F ;IN NOISE FILTER ASSY, EMC	
41 42 43 44 45 46 47 48 49 50 51 52	S40620000 0A4400605 S40621000 S40622000 149809000 S40621000 S40622000 149809000 S40623000 0A5401606 025040236 021400106	1 6 1 1 2 3 2 5 1 1 1 1	<単相230V,三相400V用> キバントリツケイタ +ナベザクミ4X6DA EMIコアESD-SR-15 EMIコアESD-SR-25 タイラツPL EMIコアESD-SR-15 EMIコアESD-SR-25 タイラツPL EMIコアTR-40-27 +ナベザクミ4X16DB ヒラザガネチユウ4 ナツト1シユ4	<For " 1-Phase 230V AC & 3-Phase 400V AC "> SETTING PLATE, ;PCB SCREW, PAN (S/P WASHER) M4X6 EMI CORE, ESD-SR-15 EMI CORE, ESD-SR-25 BEAD BAND, L= 200 EMI CORE, ESD-SR-15 EMI CORE, ESD-SR-25 BEAD BAND, L= 200 EMI CORE, TR-40-27 SCREW, PAN (S/P WASHER) M4X16 WASHER, PLAIN M 4 NUT, 1 M4	

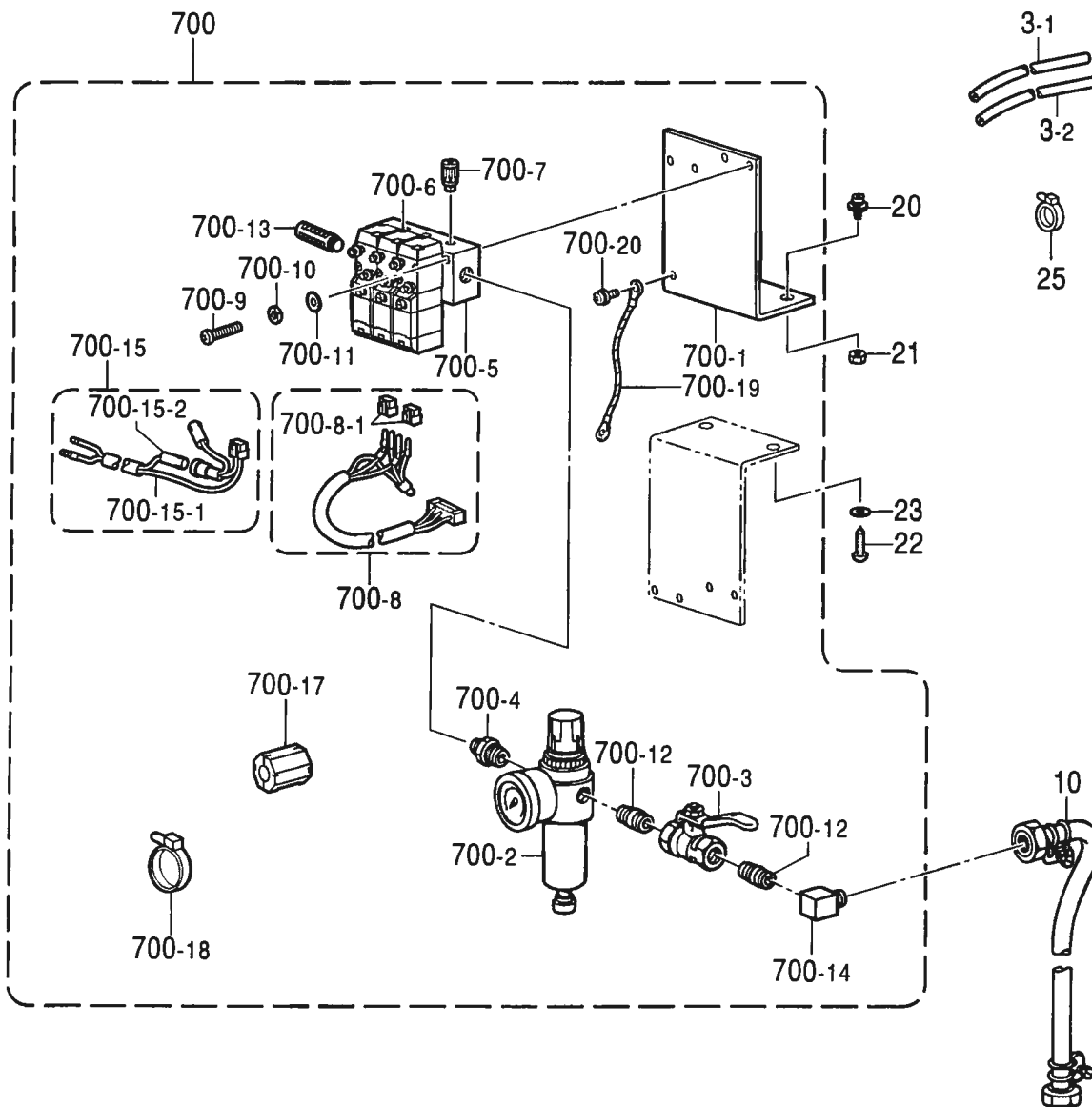
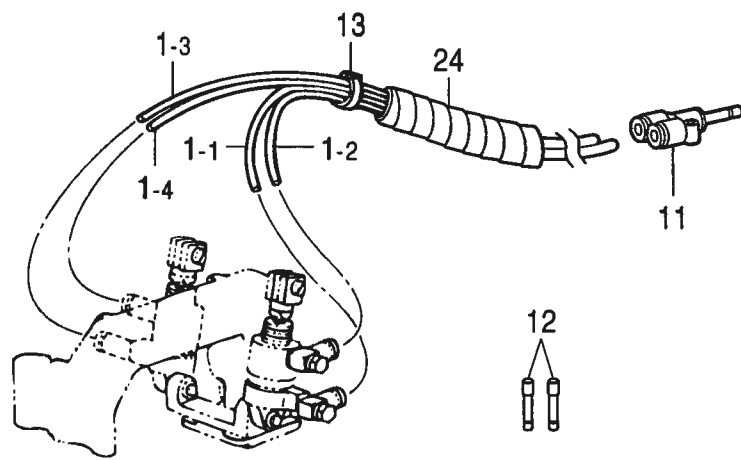

R. 空圧関係 / Air pressure mechanism

REF.NO.	CODE	Q'TY	ヒンメイ	NAME OF PARTS	RM
1-1	S43687001	1	ナイロンチューブR	AIR TUBE, AR-1A L = 1450	
1-2	S43687002	1	ナイロンチューブR	AIR TUBE, AR-1B L = 1450	
1-3	S43688001	1	ナイロンチューブL	AIR TUBE, AR-2A L = 1350	
1-4	S43688002	1	ナイロンチューブL	AIR TUBE, AR-2B L = 1350	
3-1	S53118001	1	ナイロンチューブ	AIR TUBE, RV-3A L = 1600	
3-2	S53118002	1	ナイロンチューブ	AIR TUBE, RV-3B L = 1600	
10	149796001	1	ゴムホースカナグツキ	AIR HOSE, W/CONNECTOR	
11	S08178000	2	ブランチUY-4	BRANCH, UY-4	
12	S04897000	2	プラグ4	PLUG, 4	
13	228475000	3	ケツソクバンド1.9X80	FASTENING BAND, 1.9X80	
20	052501205	2	ナベコバネヒラ5X12	SCREW, PAN (S/P WASHER) M5X12	
21	021500106	2	1シユナツト5	NUT, 1 M5	
22	032422003	2	+マルモクネシ4 1X20	WOOD SCREW, ROUND M4.1X20	
23	148847001	2	ザガネ	WASHER, PLAIN 4.76	
24	S12212000	1	スハイル290S	SPIRAL, 290S	
25	228475000	2	ケツソクバンド1.9X80	FASTENING BAND, 1.9X80	
700	S51854209	1	デンジバルブ3Aクミ	VALVE ASSY, 3A	
700-1	S31551209	1	バルブトリツケイタ2-3	SETTING PLATE, 2-3 ; VALVE	
700-2	S09318101	1	インテグレータ	INTEGRATER	
700-3	S40628000	1	ボールバルブ1/4	BALL VALVE, 1/4	
700-4	S09228000	1	イケイツフル	NIPPLE, 1/4X1/8	
700-5	S44748001	1	エアマニホルト3	AIR MANIFOLD, 3	
700-6	S43683001	3	デンジバルブ	SOLENOID VALVE	
700-7	S18415101	6	ハーフユニオンQ4M5	HALF UNION, ; Q4M5	
700-8	S43682100	1	バルブハーネスX2クミ	VALVE HARNESS ASSY, X2	
700-8-1	S12404000	2	クロダバルブコネクタ	VALVE CONNECTOR	
700-9	062302506	2	ナベコ3X25	SCREW, PAN M3X25	
700-10	028030242	2	バネザガネ2-3	WASHER, SPRING 2-3	
700-11	025030232	2	ヒラザガネチユウ3	WASHER, PLAIN M 3	
700-12	S40629000	2	バレルニツフル	BARREL NIPPLE	
700-13	S23880000	2	エアーマフラー	AIR MUFFLER	
700-14	S43686000	1	PTエルボ1/4	ELBOW, PT 1/4	
700-15	S43696100	1	バルブハーネスX1クミ	VALVE HARNESS ASSY, X1	
700-15-1	S44746100	1	ツイカバルブハーネス	VALVE HARNESS	
700-15-2	S44750100	1	ツイカバルブハーネス24V	VALVE HARNESS, 24V	
700-17	S40622000	1	EMIコアESD-SR-25	EMI CORE, ESD-SR-25	
700-18	149809000	1	タイラツフル	BEAD BAND, L = 200	
700-19	S44287000	1	アースセン1050	GROUND WIRE, 1050	
700-20	0A5400806	1	+ナヘザクミ4X8DB	SCREW, PAN (S/P WASHER) M4X8	

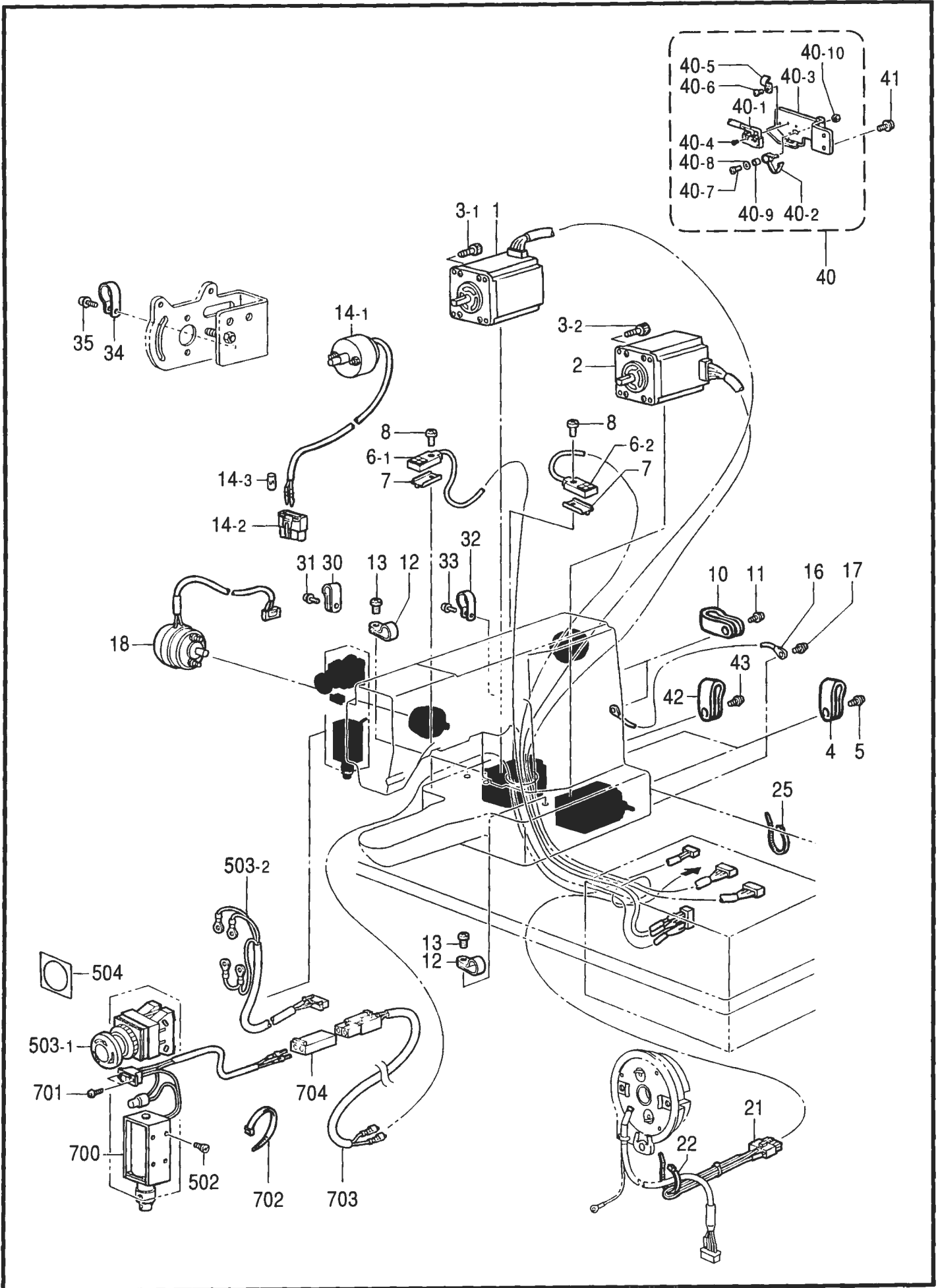

S. 電装品関係 / Power supply equipment mechanism

REF.NO.	CODE	Q'TY	ヒンメイ	NAME OF PARTS	RM
1	S48587000	1	ハルスモータXクミ	PULSE MOTOR ASSY, X	
2	S48589000	1	ハルスモータYクミ	PULSE MOTOR ASSY, Y	
3-1	155055001	4	アナホルト4X45	BOLT, SOCKET M4X45	
3-2	018402522	4	アナホルト4X25	BOLT, SOCKET M4X25	
4	552907000	2	コードホルダ#10	CORD HOLDER, 10N	
5	0A5401006	2	ナベコバネヒラ4X10	SCREW, PAN (S/P WASHER) M4X10	
6	S53136000	1	トウブセンサエアークミ	SENSOR ASSY, ;HEAD AIR	
6-1	S44665000	1	キンセツセンサGL-12F	PROXIMITY SENSOR, GL-12F ;X	
6-2	S44665001	1	キンセツセンサGL-12F	PROXIMITY SENSOR, GL-12F ;Y	
7	S46476001	2	センサカナグ	SENSOR BRACKET	
8	062300806	2	ナベコ3X8	SCREW, PAN M3X8	
10	552907000	2	コードホルダ#10	CORD HOLDER, 10N	
11	0A5401006	2	ナベコバネヒラ4X10	SCREW, PAN (S/P WASHER) M4X10	
12	625010000	3	ナイロンクランフNK-2N	CORD HOLDER, NK-2N	
13	062670512	3	ナベコ357-40X5	SCREW, PAN SM3.57-40X5	
14-1	S38144100	1	イトキリソレノイドクミ	SOLENOID ASSY, TR	
14-2	S38146000	1	コネクタ3191-04R	CONNECTOR, 3191-04R	
14-3	S38147000	1	マークチューブ5	MARK TUBE, 5	
16	S38148000	1	アースセン1	GROUND WIRE, 1	
17	0A5400806	1	+ナベザクミ4X8DB	SCREW, PAN (S/P WASHER) M4X8	
18	S49464000	1	イトトリソレノイドクミ	SOLENOID ASSY, ;T/WIPER	
21	S49465012	1	シヨウキリカエコネクタクミ	CONNECTOR ASSY, ;434E SF	
22	228475000	1	ケツソクバント1.9X80	FASTENING BAND, 1.9X80	
25	218859001	1	バインダM150	BINDER, M150	
30	149287000	4	ナイロンクランフ	CORD HOLDER, 7N	
31	0A5400806	4	+ナベザクミ4X8DB	SCREW, PAN (S/P WASHER) M4X8	
32	S00480000	1	コードホルダ#5	CORD HOLDER, 5N	
33	0A5400806	1	+ナベザクミ4X8DB	SCREW, PAN (S/P WASHER) M4X8	
34	S00480000	2	コードホルダ#5	CORD HOLDER, 5N	
35	0A5400806	2	+ナベザクミ4X8DB	SCREW, PAN (S/P WASHER) M4X8	
40	S55629001	1	トウブスイツチクミ	HEAD POSITION SWITCH ASSY	
40-1	S55630001	1	マイクロスイツチクミ	MICRO SWITCH ASSY	
40-2	S38744001	1	スイツチイタハネ	SPRING, SWITCH PLATE	
40-3	S55632001	1	スイツチダイ	SWITCH BRACKET	
40-4	062020806	2	ナベコ2X8	SCREW, PAN M2X8	
40-5	140647101	1	コードオサエ	CORD HOLDER	
40-6	062400616	1	ナベコM4X6	SCREW, PAN M4X6	
40-7	062401216	1	ナベコM4X12	SCREW, PAN M4X12	
40-8	026040236	1	ヒラザガネミガキ4	WASHER, PLAIN 4	
40-9	154514001	1	スヘーサー	SPACER	
40-10	021400106	1	ナット1シユ4	NUT, 1 M4	
41	0A5401006	2	ナベコバネヒラ4X10	SCREW, PAN (S/P WASHER) M4X10	
42	552907000	1	コードホルダ#10	CORD HOLDER, 10N	
43	0A5401006	1	ナベコバネヒラ4X10	SCREW, PAN (S/P WASHER) M4X10	
502	062300612	4	ナベコ3X6	SCREW, PAN M3X6	
503	S49482000	1	EMロックSWハーネスクミ	EM-LOCK SWITCH & HARNESS ASSY	
503-1	S32335100	1	SW-AVS311N	SWITCH, ;AVS311N	
503-2	S49466000	1	EMSWハーネス	EM-SWITCH HARNESS	
504	S37057001	1	EMスイツチスヘーサ3	SPACER, 3 ;EM-SWITCH	
700	S41202151	1	イトハラソレノイドクミ	THREAD WIPER SOLENOID ASSY	
701	062300612	2	ナベコ3X6	SCREW, PAN M3X6	
702	228475000	2	ケツソクバンド1.9X80	FASTENING BAND, 1.9X80	
703	S55432000	1	ワイハーチュウケイハーネス	RELAY HARNESS, WIPER	
704	S55433000	1	コネクタ3191-02P1	CONNECTOR:3191-02P1	

T. 操作パネル関係 / Operation panel mechanism

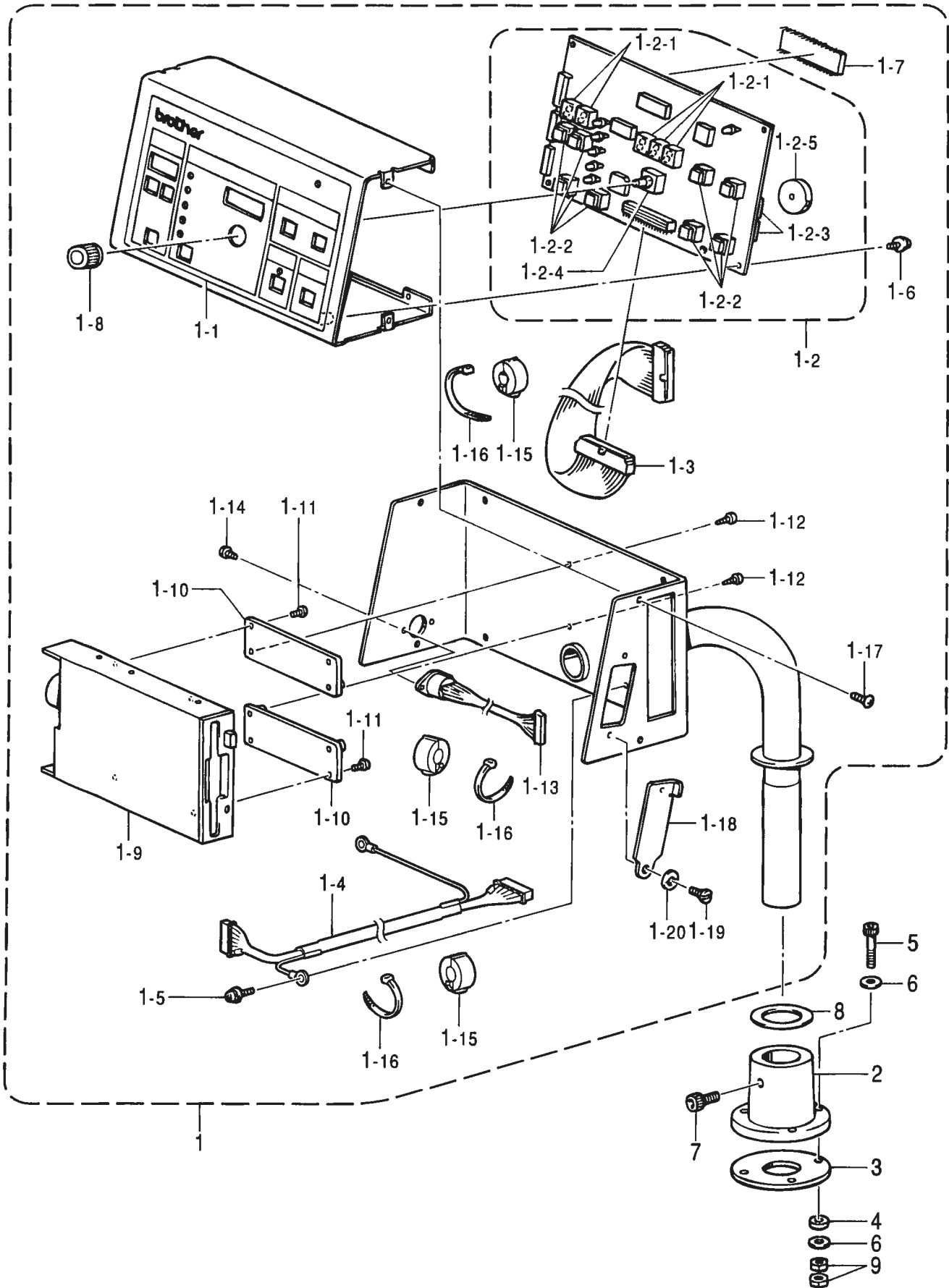

T. 操作パネル関係 / Operation panel mechanism

REF.NO.	CODE	Q'TY	ヒンメイ	NAME OF PARTS	RM
1	S55405001	1	ソウサハネルクミ	OPERATION PANEL ASSY	
1-1	S56522000	1	ソウサハネルフィルム	FILM, OPERATION PANEL	
1-2	S51801001	1	ハネルキバンクミ	PANEL PCB ASSY	
1-2-1	S29023000	5	LEDGL9P040	LED, ;GL9P040	
1-2-2	S30260002	8	SWDP1-100	SWITCH, DP1-100 ;GRAY	
1-2-3	U34870001	2	DIPSW KSP08	DIP SWITCH:KSP08	
1-2-4	S38104000	1	エンコーダEVQVEMF01	ENCODER, EVQVEMF01	
1-2-5	417382001	1	PKB245C-3601	BUZZER:PKB245C-3601	
1-3	S43226000	1	FDDハーネス	FDD HARNESS	
1-4	S55402000	1	ハネルコードクミ	PANEL HARNESS ASSY	
1-5	0A5400805	1	+ナベザクミ4X8DB	SCREW, PAN (S/P WASHER) M4X8	
1-6	0A4300605	4	+ナベザクミ3X6DA	SCREW, PAN (S/P WASHER) M3X6	
1-7	S43237100	1	PROMハネルクミ	PROM ASSY, PANEL	
1-8	S02907000	1	ツマミ	KNOB	
1-9	S43224000	1	3.5FDD	FDD, 3.5	
1-10	S43225000	2	FDDスヘーサ	SPACER, FDD	
1-11	0A4300605	4	+ナベザクミ3X6DA	SCREW, PAN (S/P WASHER) M3X6	
1-12	037300816	4	Vナベタツヒン3X8	TAPPING SCREW, PAN V M3X8	
1-13	S43228000	1	プログラマコードPクミ	PROGRAMMER HARNESS ASSY, P	
1-14	002300603	2	+ナベコ3X6	SCREW, PAN M3X6	
1-15	S42653000	3	コアTFC-23-11-14	CORE, ;TFC-23-11-14	
1-16	149809000	4	タイラツフL	BEAD BAND, L = 200	
1-17	008400604	8	+トラスコ4X6	SCREW, TRUSS M4X6	
1-18	S36008009	1	ハネルヨコカバー	SIDE COVER, ;PANEL	
1-19	107321009	1	ダンネシ4.76	SHOULDER SCREW, SM4.76	
1-20	107017001	1	ナミバネザカネ	WASHER, SPRING WAVE	
2	S43236009	1	ソウサハネルトダイ	OPERATION PANEL BASE	
3	S43674000	1	クツシヨンA	CUSHION, A	
4	S43675000	3	クツシヨンB	CUSHION, B	
5	S25634101	3	アナボルト5X65	BOLT, SOCKET M5X65	
6	025050236	6	ヒラザガネチユウ5	WASHER, PLAIN M 5	
7	018081636	1	アナボルト8X16	BOLT, SOCKET M8X16	
8	S10408000	1	ゴムシート	RUBBER SHEET	
9	021500106	6	1シユナツト5	NUT, 1 M5	

U1 . 踏板關係 / Foot switch pedal mechanism

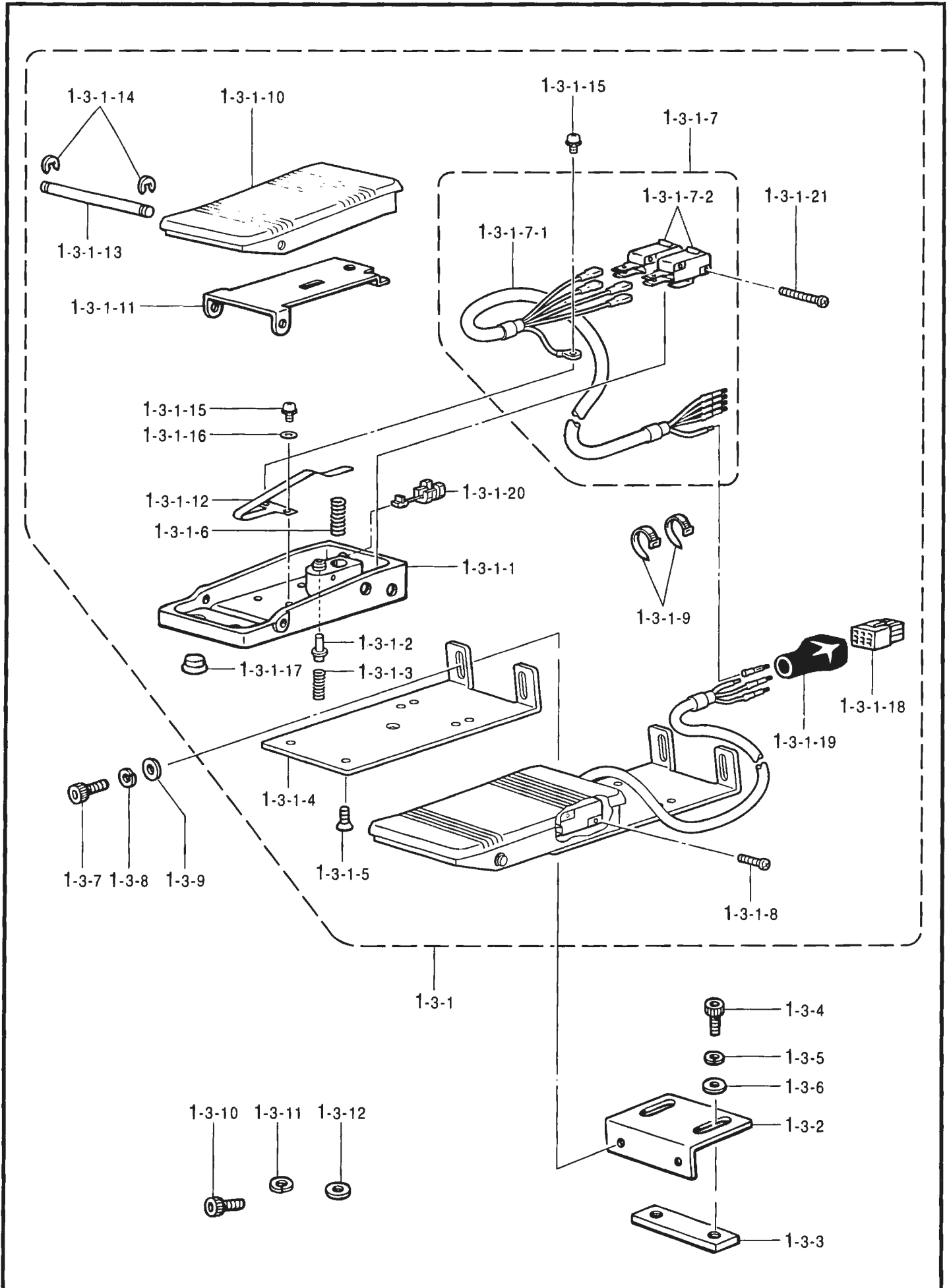

U1 . 踏板関係 / Foot switch pedal mechanism

REF.NO.	CODE	Q'TY	ヒンメイ	NAME OF PARTS	RM
1-3	S51846101	1	2レンフット3SWセット	2-PEDAL FOOT SW SET, 3	
1-3-1	S51847101	1	2レンフット3SWクミ	2-PEDAL FOOT SW ASSY, 3	
1-3-1-1	S49669100	2	フットヘダルダイクミ	FOOT PEDAL BASE ASSY	
1-3-1-2	S49672001	1	2ダンSWヒン	PIN	
1-3-1-3	S38168001	1	アツシユクハネ	SPRING, COMPRESSION	
1-3-1-4	S38169201	2	フットSWシジイタB	SUPPORT PLATE, B ;F-SWITCH	
1-3-1-5	004400603	4	+ サラコネシ4X6	SCREW, FLAT M4X6	
1-3-1-6	S38170001	2	フットヘダルハネ	SPRING, COMPRESSION	
1-3-1-7	S54650000	1	2レンフット3SWハーネスクミ	FOOT SW HARNESS ASSY, 2-P/3	
1-3-1-7-1	S54691000	1	2レンフット3SWハーネス	FOOT SW HARNESS, 2-P/3	
1-3-1-7-2	S36260000	3	スイツチVXヒンホタン	MICRO SWITCH, VX ;PIN BUTTON	
1-3-1-8	062301205	2	ナエコ3X12	SCREW, PAN M3X12	
1-3-1-9	228475000	8	ケツソクバンド1.9X80	FASTENING BAND, 1.9X80	
1-3-1-10	S51451000	2	フットヘダル	FOOT PEDAL	
1-3-1-11	S49673000	2	ヘダルホコイタ	PROTECTION PLATE, ;PEDAL	
1-3-1-12	S49674001	2	スイツチオサエハネ	SPRING, PLATE	
1-3-1-13	S38177001	2	フットヘダルシク	SHAFT, ;F-PEDAL	
1-3-1-14	048050346	4	トメワE5	RETAINING RING, E5	
1-3-1-15	052400606	4	ナエコハネヒラ4X6	SCREW, PAN (S/P WASHER) M4X6	
1-3-1-16	025040236	2	ヒラザカネチユウ4	WASHER, PLAIN M 4	
1-3-1-17	117936001	8	ゴムセン9.4	RUBBER CAP, 9.4	
1-3-1-18	S38180000	1	コネクタ172169-1	CONNECTOR, ;172169-1	
1-3-1-19	S38060000	1	コネクタキヤツフ18X19	CONNECTOR CAP, 18X19	
1-3-1-20	S46694000	2	コードブツシユKR61A	CORD BUSH, KR61A	
1-3-1-21	062302506	2	ナエコ3X25	SCREW, PAN M3X25	
1-3-2	S38178101	2	フットSWシシイタA	SUPPORT PLATE, A	
1-3-3	S38179101	2	フットSWシシイタC	SUPPORT PLATE, C	
1-3-4	018082536	4	アナボルト8X25	BOLT, SOCKET M8X25	
1-3-5	028080246	4	ハネザガネ2-8	WASHER, SPRING 2-8	
1-3-6	025080236	4	ヒラザガネチユウ8	WASHER, PLAIN M 8	
1-3-7	018501036	4	アナボルト5X10	BOLT, SOCKET M5X10	
1-3-8	028050246	4	ハネザガネ2-5	WASHER, SPRING 2-5	
1-3-9	025050236	4	ヒラザガネチユウ5	WASHER, PLAIN M 5	
1-3-10	018401236	4	アナボルト4X12	BOLT, SOCKET M4X12	
1-3-11	028040246	4	ハネザガネ2-4	WASHER, SPRING 2-4	
1-3-12	025040236	4	ヒラザガネチユウ4	WASHER, PLAIN M 4	

U2 . 踏板関係 (オプション部品) / Foot switch pedal mechanism (Option parts)

" オプション部品 / OPTION PARTS "

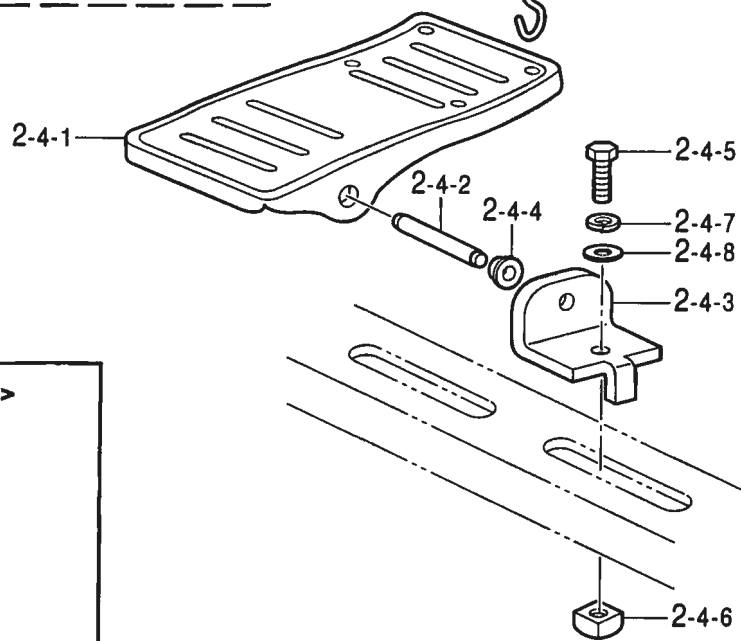
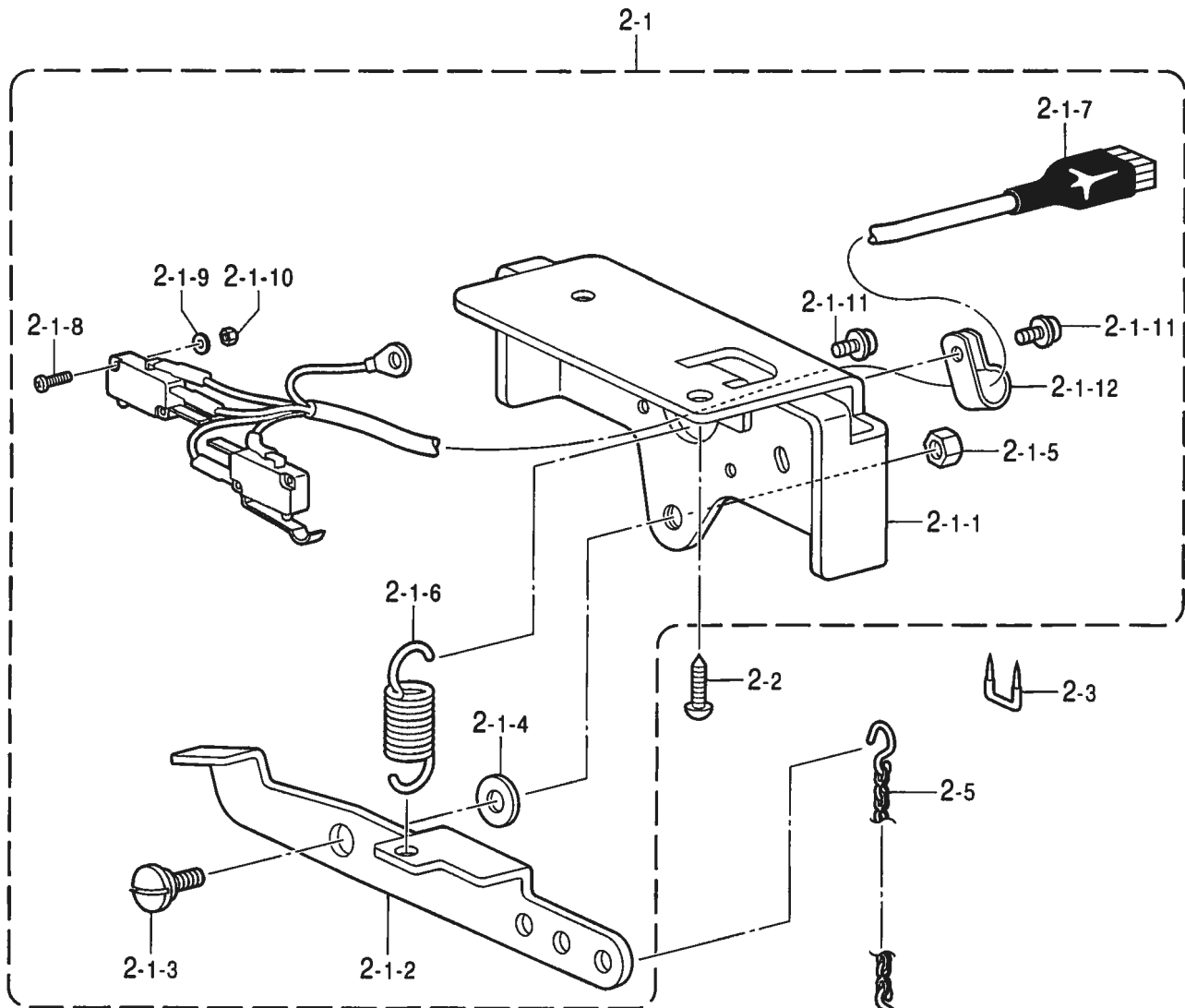

< 補給用部品 / For supply parts >

3

U2 . 踏板関係 (オプション部品) / Foot switch pedal mechanism (Option parts)

REF.NO.	CODE	Q'TY	ヒンメイ	NAME OF PARTS	RM
			" オプション部品 "	" OPTION PARTS "	
2	S46131001	1	2ダンフットSWセットOP	2-STEP FOOT SWITCH SET, OP	
2-1	S46132001	1	2ダンフットSWクミOP	2-STEP FOOT SWITCH ASSY, OP	
2-1-1	S46133001	1	SWササエダイ	SWITCH BRACKET	
2-1-2	S46134001	1	フットSWレバー	FOOT SW LEVER	
2-1-3	148904001	1	ダンネシ7.94	SHOULDER SCREW, SM7.94	
2-1-4	025080236	1	ヒラザガネチユウ8	WASHER, PLAIN M 8	
2-1-5	101268002	1	ナツト7.94	NUT, SM7.94	
2-1-6	S46135001	1	フットSWバネ	SPRING, EXTENSION	
2-1-7	S46136000	1	フットSWハーネスクミOP	FOOT SW HARNESS ASSY	
2-1-8	UD2390001	4	+ナヘセムス3X20DA	SCREW, PAN (S/P WASHER) M3X20	
2-1-9	025030236	2	ヒラザガネチユウ3	WASHER, PLAIN M 3	
2-1-10	021300206	2	2シユナツト3	NUT, 2 M3	
2-1-11	052400806	2	ナヘコバネヒラ4X8	SCREW, PAN (S/P WASHER) M4X8	
2-1-12	S00480000	1	コードホルダ#5	CORD HOLDER, 5N	
2-2	100666002	2	マルモクネシ5.5X20	WOOD SCREW, ROUND M5.5X20	
2-3	200190001	3	ステツフル	STAPLE	
2-4	S01603009	1	オサエアゲフミイタクミ	TREADLE ASSY	
2-4-1	S01199003	1	オサエアゲフミイタ	TREADLE PEDAL	
2-4-2	133188001	1	オサエアゲフミイタジク	TREADLE SHAFT	
2-4-3	119707003	2	フミイタシクウケ	BRACKET	
2-4-4	119708001	2	フミイタシクウケカラー	COLLAR	
2-4-5	017082206	2	ホルト8X22	BOLT, M8X22	
2-4-6	116694001	2	4カクナツト8	NUT, M8	
2-4-7	028080240	2	ハネザガネ2-8	WASHER, SPRING 2-8	
2-4-8	025080236	2	ヒラザガネチユウ8	WASHER, PLAIN M 8	
2-5	142656001	1	クサリクミ	CHAIN ASSY	
3	S49443000	1	< 補給用部品 > コンタクト170364-1	< For Supply parts > CONTACT, ;170364-1	

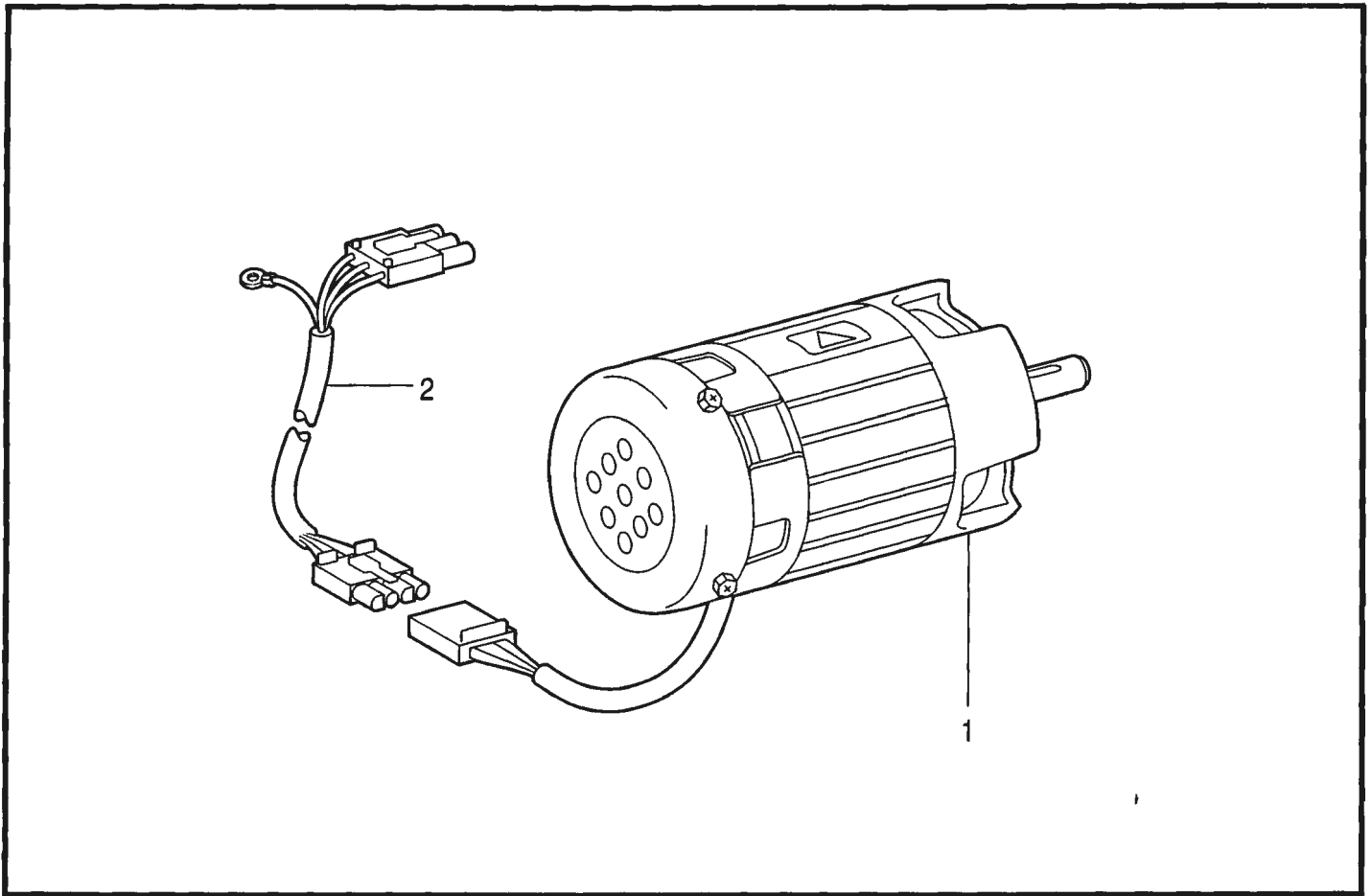

118-P34-652

W . プログラマー関係 (オプション部品) / Programmer (Option parts)

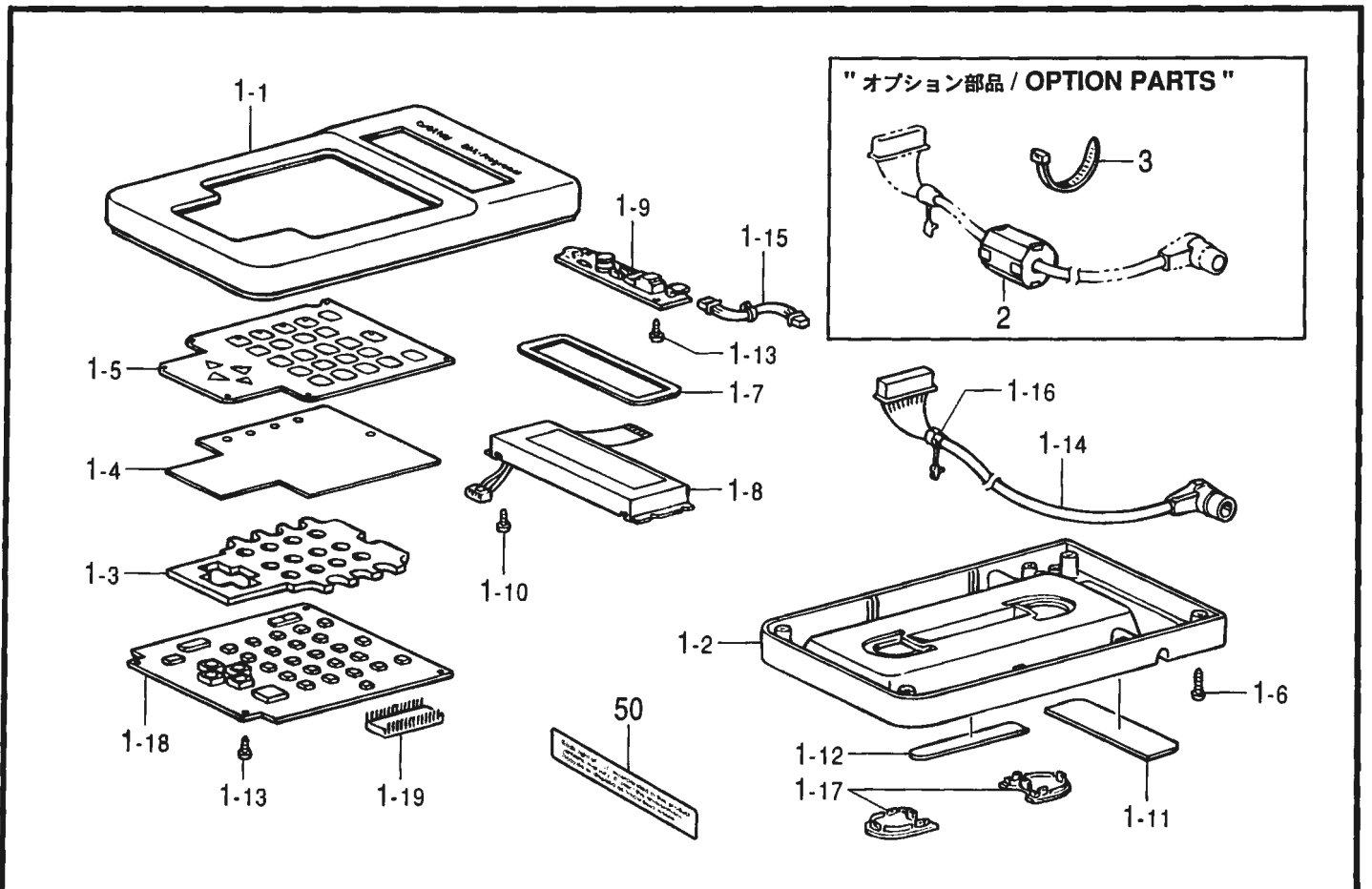

118-P34-942

V. 動力台関係 / Power table

REF.NO.	CODE	Q'TY	ヒンメイ	NAME OF PARTS	RM
1	J03647001	1	CIMモータ430クミ	MOTOR ASSY, 430CIM	
2	S53055100	1	IMハーネスクミ	HARNESS ASSY, IM	

118-P34-652

W. プログラマー関係 (オプション部品) / Programmer (Option parts)

REF.NO.	CODE	Q'TY	ヒンメイ	NAME OF PARTS	RM
1	S43249001	1	プログラマクミ	PROGRAMMER ASSY	
1-1	S43250000	1	プログラマーウエフタ	TOP COVER, ;PROGRAMMER	
1-2	S43251000	1	プログラマーシタフタ	LOWER COVER, ;PROGRAMMER	
1-3	S43252000	1	キーボードスヘーサ	SPACER, ;KEYBOARD	
1-4	S43253000	1	キーボードゴムシート	RUBBER SHEET, ;KEYBOARD	
1-5	S43254000	1	キーボードシート	KEYBOARD SHEET	
1-6	037301015	4	Vナベタツヒン3X10	TAPPING SCREW, PAN V M3X10	
1-7	S43255000	1	LCDカバー	LCD COVER	
1-8	S43256000	1	LCD	LCD	
1-9	S43257000	1	LCDヨウインバーター	INVERTER, LCD	
1-10	037200615	40	Vナベタツヒン2X6	TAPPING SCREW, PAN V M2X6	
1-11	S43271000	1	プログラマーマグネットA	MAGNET, A	
1-12	S43272000	1	プログラマーマグネットB	MAGNET, B	
1-13	037300615	6	Vナベタツヒン3X6	SCREW 3X6	
1-14	S43267000	1	プログラマーコード	PROGRAMMER HARNESS	
1-15	S43268000	1	インバーターハーネス	INVERTER HARNESS	
1-16	S43270000	1	コードブツシユKR51	CORD BUSH, ;KR51	
1-17	S43981000	2	プログラマーシタカバー	LOWER COVER, PROGRAMMER	
1-18	S43259001	1	プログラマキバンクミ	PROGRAMMER PCB ASSY	
1-19	S43269000	1	PROMプログラマクミ	PROM PROGRAMMER ASSY	
2	S40621000	1	" オプション部品 "	" OPTION PARTS "	
3	149809000	1	EMIコアESD-SR-15	EMI CORE, ESD-SR-15	
		1	タイラツフL	BEAD BAND, L = 200	
50	S52582001	1	<地域限定用> スイギンケイコクラベルP2	<For Area limitation> MERCURY WARNING LABEL 14X70 P2	

118-P34-942

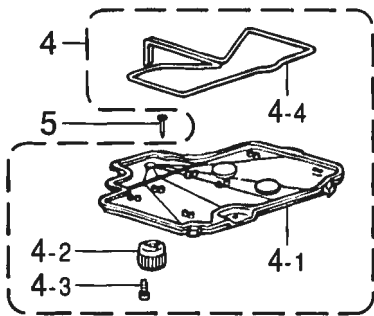

21
20

103
101 102

16

18-1
-2
-3

921
920 59

17

75-1
-2
76
71
70

6

98
96
97

12 10
11 9

55
53
52

51

31
30
29

19

54
57
56
58

67-1-7
67-1-6
67-1-3
67-1-1
67-1-4
67-1-5
67-1-2
67-1
67-2

25
26
27
28

23

33
34

64

35

22

14

35-5-1
35-5
35-10-2
35-10-3
35-10-1
35-4-5
35-11-1
35-11-5
35-11-2
35-11-4
35-7
35-11-3
35-11-1
35-8-1
35-11-4
35-6
35-11-5
35-2
35-3
35-1
35-8-2
35-9
35-8-3
35-4-4
35-4-1
35-4-2
35-4-3

" オプション部品 / OPTION PARTS "

15

93

91
92

Z. 付属品関係 / Accessories

REF.NO.	CODE	Q'TY	ヒンメイ	NAME OF PARTS	RM
4	S38039209	1	オイルハンクミ	OIL PAN ASSY	
4-1	S38040209	1	オイルハン	OIL PAN	
4-2	154467001	1	ハイユキヤツフ	DUST OILER	
4-3	037301215	2	Vナヘタツピン3X12	TAPPING SCREW, PAN V M3X12	
4-4	S18093100	1	クミヒモ4X4	WICK, 4X4 L = 1100	
5	109714000	5	クギ	NAIL	
6	114486002	1	ホリオイラータイ	OILER	
9	143882001	2	トウブヒンシ	HEAD HINGE	
10	014760622	2	アナトメネシ5.95	SET SCREW, SOCKET SM5.95	
11	S49603000	2	トウブヒンシウケゴム	RUBBER CUSHION	
12	109714000	4	クギ	NAIL	
14	122991001	1	フソクヒンホリフクロ	ACCESSORY BAG	
16	☆	3	ホビン	BOBBIN	
17	☆	1	ミシンハリクミ	NEEDLE ASSY	
18-1	S10208001	1	イトウハカンザ <t=0.4>	SPACER, MOVABLE KNIFE T = 0.4 .. <t=0.4>	
18-2	S10208002	1	イトウハカンザ .. <t=0.5>	SPACER, MOVABLE KNIFE T = 0.5 .. <t=0.5>	
18-3	S10208003	1	イトウハカンザ ... <t=0.6>	SPACER, MOVABLE KNIFE T = 0.6 .. <t=0.6>	
19	S38045109	1	マクラクミ	HEAD REST ASSY	
20	S49604000	2	トウブウケゴム	RUBBER	
21	109714000	2	クギ	NAIL	
22	114483002	1	ホリオイラークミ	OILER ASSY	
23	S55663001	1	オイルタンククミ	OIL TANK ASSY	
25	149173001	1	6カクハウネシマワシ3	SCREW DRIVER, HEXAGONAL 3	
26	142443001	1	ネシマワシ1.9X52	SCREW DRIVER, 1.9X52	
27	118837001	1	ネシマワシ3.4X70	SCREW DRIVER, 3.4X70	
28	101572101	1	ネシマワシ5.5X190	SCREW DRIVER, 5.5X190	
29	107779001	1	スハナ6X7	WRENCH, 6X7	
30	100887001	1	スハナ8X9	WRENCH, 8X9	
31	107780001	1	スハナ10X12	WRENCH, 10X12	
33	142721001	1	6カクハウスハナ3	ALLEN WRENCH 3	
34	118064001	1	6カクハウスハナ4	HEXAGONAL WRENCH, 4	
35	S02763402	1	イトタテダイクミ2DR	COTTON STAND ASSY, 2DR	
35-1	S51283001	2	ウケザラ	SPOOL STAND BASE	
35-2	150182000	2	スフールマット	SPOOL MAT	
35-3	S51282001	2	スフールクツシヨン	SPOOL CUSHION	
35-4	S02777001	1	ハイフDネシセットB	PIPE (D) & SCREW SET, B	
35-4-1	150206002	1	ヒラザガネ16	WASHER, PLAIN 16	
35-4-2	S38648001	1	6カクナツトU5/8	NUT, U5/8-28	
35-4-3	150174000	1	コラムキヤツフ	COLUMN CAP	
35-4-4	S01005000	2	イトタテゴム	RUBBER WASHER	
35-4-5	S02747101	1	イトカケバネ	SPRING	
35-5	S40640001	1	コラムハイフキヤツフツキ	COLUMN PIPE W/CAP	
35-5-1	150174000	1	コラムキヤツフ	COLUMN CAP	
35-6	156112003	1	コラムハイフD	COLUMN PIPE, D	
35-7	150173003	1	コラムジョイント	COLUMN JOINT	
35-8	S21798001	2	スフールネシセット	SPOOL & SCREW SET	
35-8-1	150179002	2	スフールジクB	SPOOL SHAFT, B	
35-8-2	028050246	2	バネザガネ2-5	WASHER, SPRING 2-5	
35-8-3	021500106	2	1シュナツト5	NUT, 1 M5	
35-9	S02778002	1	スフールホルダー2	SPOOL HOLDER, 2	
35-10	S02786002	1	スレツドハンガークミ2	THREAD HANGER ASSY, 2	
35-10-1	S02787002	1	スレツドハンガー2	THREAD HANGER, 2	
35-10-2	150183000	2	イトカケハンガーダイ	THREAD HANGER BASE	
35-10-3	142990001	2	スレツドブツシュ	THREAD BUSH	
35-11	S40641001	1	スフールジクネシセットA	SPOOL SHAFT & SCREW SET, A	
35-11-1	021500106	4	1シュナツト5	NUT, 1 M5	

118-P34-910

◎ 付属品の明細は変更することがあります。

◎ The details of included accessories are subject to change.

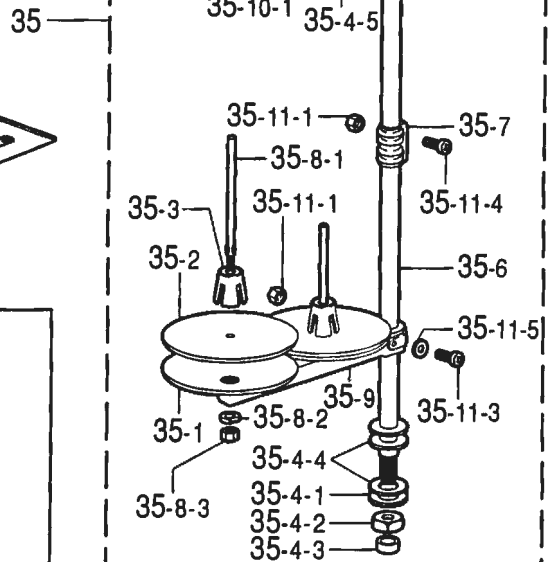
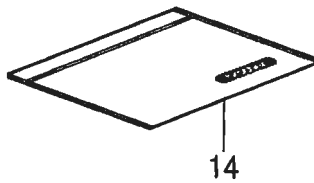
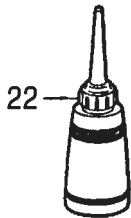
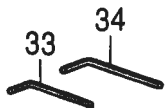
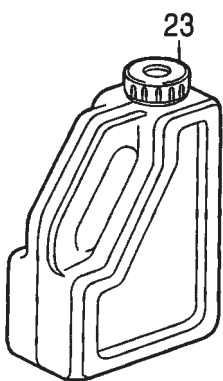
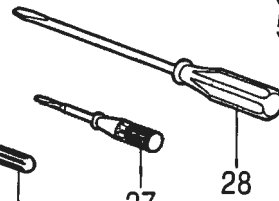
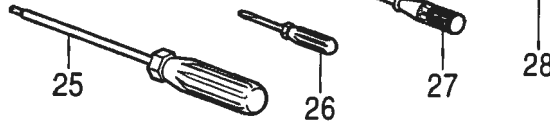
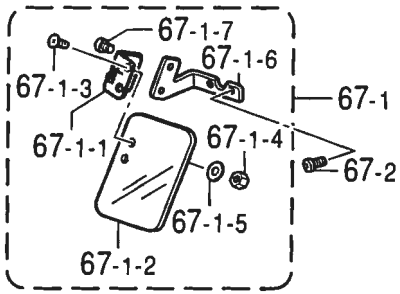
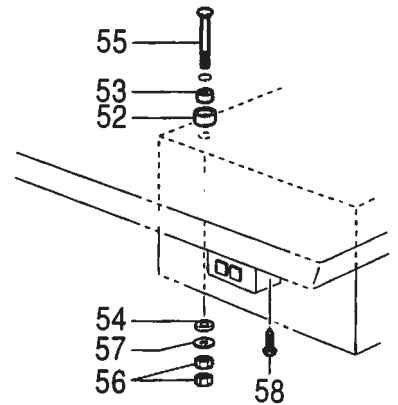
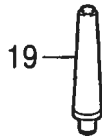
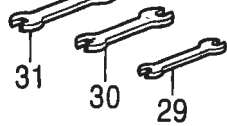
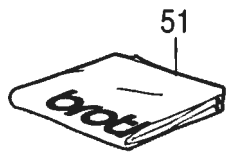
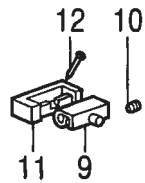
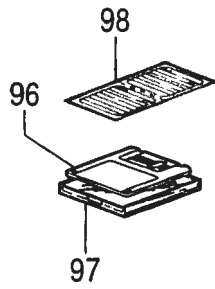
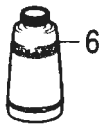
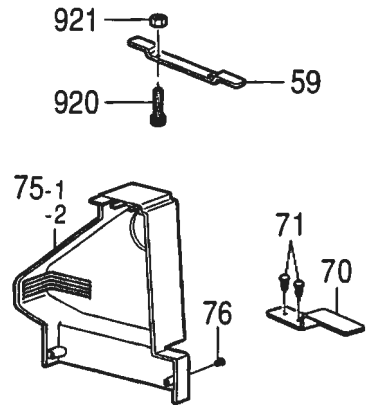
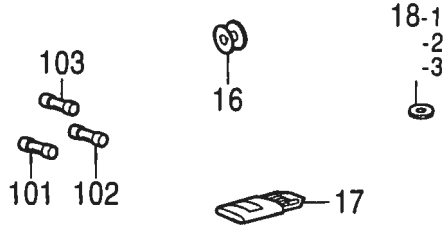
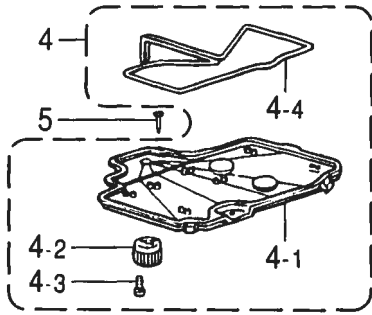

" オプション部品 / OPTION PARTS "

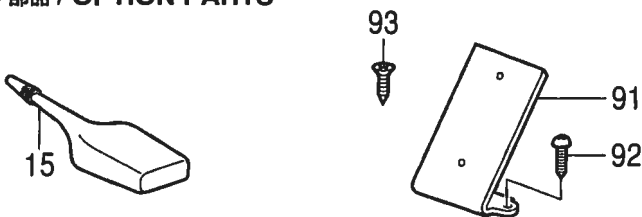

Z. 付属品関係 / Accessories

REF.NO.	CODE	Q'TY	ヒンメイ	NAME OF PARTS	RM
35-11-2	062501406	1	ナヘコ5X14	SCREW, PAN M5X14	
35-11-3	062503506	1	ナヘコM5X35	SCREW, PAN M5X35	
35-11-4	062501406	2	ナヘコ5X14	SCREW, PAN M5X14	
35-11-5	026050136	2	ヒラザガネコガタ5	WASHER, PLAIN S 5	
51	144226001	1	トウフカバー	HEAD COVER	
52	146256001	4	クッションカナグ	CUSHION COLLAR	
53	146255000	4	クッション	CUSHION	
54	S00617000	4	ボウシンコムカラー	RUBBER COLLAR	
55	133740006	4	カクネホルト6X70	BOLT, SQUARE M6X70	
56	021060106	8	1シユナツト6	NUT, 1 M6	
57	025060336	4	ヒラザガネダイ6	WASHER, PLAIN L 6	
58	032461606	2	+ マルモクネジ4.5X16	WOOD SCREW, ROUND M4.5X16	
59	S38044001	1	ヒンシオサエ	HINGE PRESSER	
64	S41222101	1	ハリホワイトアンナイB	THREAD GUIDE, B ;N-BAR	
67	S49602201	1	アイガードセットC	EYE GUARD SET, C	
67-1	S44493101	1	アイカードクミ	EYE GUARD ASSY	
67-1-1	S44483001	1	チヨウバンクミ	HINGE ASSY	
67-1-2	S44485001	1	アイガード	EYE GUARD	
67-1-3	061660806	2	サラコ318-40X8	SCREW, FLAT SM3.18-40X8	
67-1-4	021660102	2	ナツト1シユ3.18	NUT, 1 SM3.18	
67-1-5	026030232	2	ヒラザガネミガキ3	WASHER, PLAIN M 3	
67-1-6	S44486101	1	アイガードホルダーA	EYE GUARD HOLDER, A	
67-1-7	062670512	2	ナベコ357-40X5	SCREW, PAN SM3.57-40X5	
67-2	062671016	2	ナベコ357-40X10	SCREW, PAN SM3.57-40X10	
70	S55633001	1	スイッチオシイタ	SWITCHING PLATE	
71	032422003	2	+ マルモクネジ4.1X20	WOOD SCREW, ROUND M4.1X20	
75-1	S55311001	1	<国内用> ベルトカバーIMクミ	<For Japan only>	
75-2	S55311002	1	<輸出用> ベルトカバーIMクミ	<For Export> BELT COVER ASSY, IM	
76	062401006	2	ナヘコ4X10	SCREW, PAN M4X10	
96	S43273000	1	3.5メディア2HD	3.5 MEDIA, 2HD	
97	S09989000	1	フロppyケース	FLOPPY CASE	
98	S42658000	1	3.5インデックスラベル	INDEX LABEL, 3.5FD	
101	S08030000	1	Gヒューズ5AFB	FUSE, 5A ;FB	
102	153242000	1	ヒューズ6A	FUSE, 6A	
103	S48580000	1	GFUSE7AFB	FUSE, 7A ;FB	
920	018405032	2	アナボルト4X50	BOLT, SOCKET M4X50	
921	021400102	2	ナツト1シユ4	NUT, 1 M4	
15	S06706001	1	" オプション部品 "	" OPTION PARTS "	
91	S42890001	1	シリコンオイル	SILICONE OIL	
92	032422003	2	プログラマササエ	PROGRAMMER SUPPORT	
93	0B1351606	2	+ マルモクネジ4.1X20	WOOD SCREW, ROUND M4.1X20	
		2	+ サラモク35X16	WOOD SCREW, FLAT M3.5X16	

118-P34-910

◎ 付属品の明細は変更することがあります。

◎ The details of included accessories are subject to change.

From the library of: Superior Sewing Machine & Supply LLC











Sp. 仕様別部品一覧表 / DIFFERENT PARTS LIST

下記部品が用意されていますので幅広い用途にご活用ください。





The following are standard gauge parts according to each specification.

◎表中★の部品は、LK3-B430E電子門止めミシンと共通です。☆の部品は、BAS-311Eプログラム式電子ミシンと共通です。

◎In the following table, parts marked with ★ are common with the LK3-B430E; parts with ☆ are common with the BAS-311E.

仕様 Spec.	中厚物 Medium-weight materials	厚物 Heavy-weight materials	極厚物 Extra heavy-weight materials
(J-53) 針穴板 Needle hole plate 	(ø2.2) S49980-001 FM	(ø2.6) S10212-101 E	★
(E-24) ボビンケース組 Bobbin case assy 	159610-301 A	152690-401 B	★
(E-24-1) ボビンケース調子ばね Tension spring 	154339-101 A	154340-101 B	★
(E-24-2) ボビンケースばねねじ Screw 		154341-001	★
(E-24-3) 空転防止ばね Spring, anti-spin 	159612-001 A ★	154342-001 B	★
(E-25) ボビン Bobbin 	159613-051	154663-001 B	★
(E-22) 中がま箱組 Shuttle hook assy, w/box 	152685-903 A ★	152687-902 B	★
(E-21) 大がま Shuttle race body 	152682-101 A	152686-101 B	★
(G-14) 糸調子ばね Spring, tension 	104525-001	107606-001	★
(G-10) 糸取りばね Thread take-up spring 	145519-001	144588-001 B	★

Sp. 仕様別部品一覧表 / DIFFERENT PARTS LIST

仕様 Spec. 品名 Part name	中厚物 Medium-weight materials	厚物 Heavy-weight materials	極厚物 Extra heavy-weight materials
(G-25) 針棒糸案内 Thread guide, ;n-bar 	★ S41222-101 B	☆ S02438-001 A	★ S02439-001 B
(Z-17) ミシン針組 Needle assy	★ 107415-414	★ S37928-419	☆ 145646-425
(B-26) 針 Needle 	★ DP×5 #14 107415-014	★ DP×17NY #19 S37928-019	☆ DP×17 #25 145646-025
(C3-200-1, 200-2) 押え Work clamp 	—	434E SF-2R S46544-001 — 434E SF-2L S46545-001	—
(C3-100) 送り板 Feed plate 	—	434E SF-2 S44942-001	—

Ga . ゲージ部品一覧表 / Gauge parts List

<ゲージ部品>

オプションのゲージ部品には次のものがあります。押えと送り板は、上下の組合わせになります。

- ・ 押えと送り板

< Gauge parts >

The following are provided as optional gauge parts.

Each work clamp pair are used in combination with the feed plate directly below them.

- ・ Work clamps and feed plate

	1	2	3	4
R	153493-001	S23377-001 (519)	S27836-001 (895)	156085-001 (M)
L	153498-001	S23378-001 (519)	S27837-001 (895)	156086-001 (M)
(C3-210-1, 210-2) 押え Work clamp				
(C3-110) 送り板 Feed plate	153503-001 	S23379-001 (519) 	S23838-001 (895) 	156087-001 (M)

	5	6	7		
R	156082-001 (L)	156088-001 (S)	S44940-001 (434E SF)		
L	156083-001 (L)	156089-001 (S)	S44941-001 (434E SF)		
(C3-210-1, 210-2) 押え Work clamp			(C3-210-7-1, 210-7-2) 		
(C3-110) 送り板 Feed plate	156084-001 (L) 	156090-001 (S) 	S43990-001 (A)	S43991-001 (B)	S43992-001 (C) A : t = 0.5 B : t = 1.0 C : t = 2.0

(C3-905) ゲージ組434E MK2 / Gauge assy, 434E MK2

S54984-001

原点基準板 / Home position standard plate

送り板締ねじ / Screw

Ga . ゲージ部品一覧表 / Gauge parts List

(J-53) 針穴板 / Needle hole plate

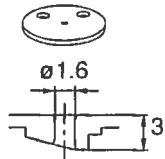
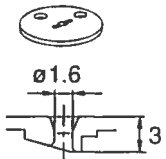
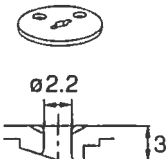
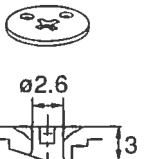
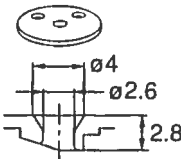
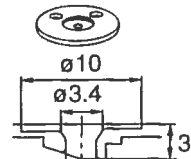
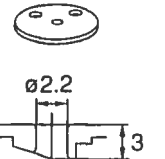
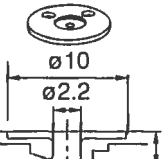
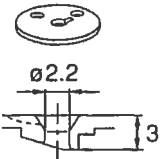
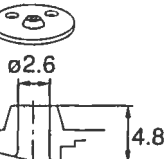
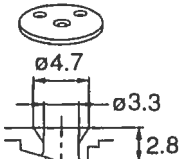
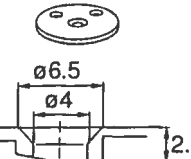
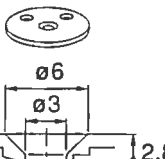
A	S10211-001	AF	S51449-001	BZ	S41013-001	D	S29997-001	E	S10212-101	ED	S30925-001
											
								(厚物用標準 / For Heavy -weight materials)			
F	S10213-001	FD	S30926-001	FM	S49980-001	H	S30450-001	L	S25127-001	M	S34348-001
											
3	S40217-001										
											

Wa. 警告ラベル / Warning labels

警告ラベル / Warning labels	品名 / Name of parts	Size(mm)	Code
	電撃ラベル・和	40 X 64	S38353-101
	Label, elec. shock 4 lang.	45 X 118	S38352-101
	操作注意ラベル・和	40 X 64	S38350-001
	Label, operation Eng.	40 X 64	S38349-001
	ラベル高温 13 X 20 Label, high temp.	13 X 20	J03663-001
	PE マーク Label, PE	7.5 X 12.5	S37059-001
	アースマーク Label, grounding	φ 12	S37060-001

索引 / INDEX

CODE	REF.NO.	Page	CODE	REF.NO.	Page	CODE	REF.NO.	Page
J02657001	Q2 - 2-1-3	40	S10208001	J - 46	26	S27838001	C3 - 110-3	14
	Q2 - 2-2-3	40		Z - 18-1	56		Ga - C3-110	61
	Q2 - 2-3-3	40	S10208002	J - 46	26	S29019000	P - 1-1	34
	Q2 - 2-4-3	40		Z - 18-2	56	S29023000	T - 1-2-1	48
	Q2 - 2-7-3	40	S10208003	J - 46	26	S29997001	Ga - J-53	62
J03647001	V - 1	54		Z - 18-3	56	S30033001	J - 22-3	26
J03663001	Wa	63	S10209101	J - 48	26		M - 5-3	32
S00480000	S - 32	46	S10210201	J - 49	28	S30260002	T - 1-2-2	48
	S - 34	46	S10211001	Ga - J-53	62	S30450001	Ga - J-53	62
	U2 - 2-1-12	52	S10212101	Ga - J-53	62	S30925001	Ga - J-53	62
S00554000	Q1 - 1-17	36		Sp - J-53	59	S30926001	Ga - J-53	62
S00617000	Z - 54	58	S10213001	Ga - J-53	62	S31012001	D - 717	16
S00705001	J - 47	26	S10371001	D - 723	16	S31013001	D - 718	16
S01005000	Z - 35-4-4	56	S10372100	D - 724	16	S31032001	G - 13	22
S01199003	U2 - 2-4-1	52	S10377101	C2 - 91-3	12	S31551209	R - 700-1	44
S01603009	U2 - 2-4	52	S10378101	C2 - 91-4	12	S31760000	Q1 - 1-18	36
S01998001	L - 8	30	S10408000	T - 8	48	S32235001	J - 18	26
S02269001	B1 - 22	4	S10469001	G - 18	22	S32335100	S - 503-1	46
S02354001	J - 24	26	S10478000	F - 10	20	S33251001	D - 790	16
	M - 3	32	S11244001	J - 52	28	S34348001	Ga - J-53	62
S02429101	E - 14-2	18	S11949000	Q1 - 1-16	36	S34883001	L - 11	30
S02438001	G - 25-3	22	S12212000	R - 24	44	S34986000	F - 11	20
	Sp - G-25	60	S12404000	R - 700-8-1	44	S36008009	T - 1-18	48
S02439001	G - 25-4	22	S12441001	G - 33	22	S36260000	U1 - 1-3-1-7-2	50
	Sp - G-25	60	S12668001	K - 703	30	S37057001	S - 504	46
S02445001	A - 701	2	S12699000	G - 11	22	S37059001	Wa	63
S02652001	J - 7	26	S13385001	K - 702	30	S37060001	Wa	63
S02654001	J - 8-1	26	S13399001	D - 727	16	S37147109	K - 708	30
S02747101	Z - 35-4-5	56	S15662992	Sp - E-22	59	S37148109	K - 710	30
S02763402	Z - 35	56	S15663991	Sp - E-22	59	S37806109	K - 514	30
S02777001	Z - 35-4	56	S15667001	Sp - E-24-3	59	S37915009	A - 12	2
S02778002	Z - 35-9	56	S15902401	Sp - E-24	59	S37928019	Sp - B-26	60
S02786002	Z - 35-10	56	S16074101	Sp - E-24-1	59	S37928419	Sp - Z-17	60
S02787002	Z - 35-10-1	56	S16290001	E - 23	18	S37932101	C1 - 1-5	8
S02907000	T - 1-8	48	S16492101	Sp - E-24-2	59		C1 - 7-2	8
S03677001	D - 728	16	S17871101	D - 708	16	S37933001	C1 - 1-6	8
S03800001	C2 - 91-19	12	S18093100	F - 26	20		C1 - 7-3	8
S04897000	R - 12	44		Z - 4-4	56	S37934001	C1 - 2	8
S04905000	M - 722-2	32	S18415101	R - 700-7	44	S37940001	C1 - 23	8
S06548001	Sp - G-14	59		C2 - 91-18	12	S37942000	C1 - 27	8
S06706001	Z - 15	58	S19748001	L - 5	30	S37944000	C1 - 28	8
S07333001	F - 2	20		L - 12	30	S37978251	E - 5	18
S07456000	F - 3	20		M - 8	32	S37983001	F - 6	20
S08030000	Z - 101	58	S20164001	A - 28	2	S37986000	F - 25	20
	Q1 - 1-26-16	36	S21775001	C2 - 91-6	12	S37987001	F - 29	20
S08178000	R - 11	44	S21798001	Z - 35-8	56	S37988000	F - 30	20
S09043000	E - 14-8	18	S23337001	A - 16	2	S37990509	H - 1	24
	F - 32	20		C3 - 210-2-2	14	S37991109	H - 1-1	24
	F - 700	20	S23378001	Ga - C3-210-2	61	S37992100	H - 1-2	24
S09212001	C1 - 3-1	8		C3 - 210-2-1	14	S37993000	H - 1-3	24
S09228000	R - 700-4	44		Ga - C3-210-1	61	S37994001	H - 1-5	24
S09318101	R - 700-2	44	S23379001	C3 - 110-2	14	S37995101	H - 1-6	24
S09989000	Z - 97	58		Ga - C3-110	61	S37996001	H - 1-8	24
S10058001	C2 - 91-5	12	S23836001	J - 8	26	S37997001	H - 1-11	24
S10091201	A - 407	2	S23880000	R - 700-13	44	S37998001	H - 1-16	24
S10111101	D - 719	16	S24729000	M - 724	32	S38002201	J - 3	26
S10112001	D - 720	16	S25127001	Ga - J-53	62	S38003101	J - 9	26
S10113301	D - 721	16	S25456001	K - 507	30	S38004002	J - 11	26
S10123001	M - 720	32	S25634101	T - 5	48	S38004003	J - 11	26
S10162201	F - 15	20	S27836001	C3 - 210-3-2	14	S38004004	J - 11	26
S10174000	H - 1-15	24		Ga - C3-210-2	61	S38011001	J - 34	26
S10195001	J - 30	26	S27837001	C3 - 210-3-1	14	S38012001	J - 40	26
S10202101	J - 41	26		Ga - C3-210-1	61	S38015001	J - 43	26

CODE	REF.NO.	Page
S38016001	J - 44	26
S38039209	Z - 4	56
S38040209	Z - 4-1	56
S38044001	Z - 59	58
S38045109	Z - 19	56
S38060000	U1 - 1-3-1-19	50
S38080001	N - 4	34
S38082001	N - 5	34
S38093000	Q1 - 1-4	36
S38104000	T - 1-2-4	48
S38107100	Q1 - 1-12	36
S38108000	Q1 - 1-13	36
S38109100	Q1 - 1-14	36
S38110000	Q1 - 1-15	36
S38112001	Q2 - 2-1	40
S38113000	Q2 - 2-1-1	40
	Q2 - 2-4-1	40
S38114000	Q2 - 2-2	40
S38115000	Q2 - 2-2-1	40
	Q2 - 2-3-1	40
	Q2 - 2-7-1	40
S38116000	Q1 - 1-23	36
S38117000	Q2 - 2-3	40
S38118000	Q2 - 2-2-2	40
S38120000	Q2 - 2-5	42
S38123000	Q2 - 3-1	40
S38126000	Q2 - 3-2-2	40
	Q2 - 3-3-2	40
S38133000	Q2 - 2-1-2	40
	Q2 - 2-3-2	40
S38143000	Q1 - 11-1	36
S38144100	S - 14-1	46
S38146000	S - 14-2	46
S38147000	S - 14-3	46
S38148000	S - 16	46
S38155000	P - 1-9	34
S38168001	U1 - 1-3-1-3	50
S38169201	U1 - 1-3-1-4	50
S38170001	U1 - 1-3-1-6	50
S38177001	U1 - 1-3-1-13	50
S38178101	U1 - 1-3-2	50
S38179101	U1 - 1-3-3	50
S38180000	U1 - 1-3-1-18	50
S38201000	Q1 - 1-26-6	36
S38203000	Q1 - 1-26-5	36
S38205000	Q1 - 1-26-9	36
S38206000	Q1 - 1-26-10	36
S38208000	Q1 - 1-26-14	36
S38349001	Wa	63
S38350001	Wa	63
S38352101	Q1 - 20	38
	Wa	63
S38353101	Q1 - 21	38
	Wa	63
S38648001	Z - 35-4-2	56
S38744001	S - 40-2	46
S39110001	C2 - 49	12
S40217001	Ga - J-53	62
S40616001	Q2 - 40-1	42
S40620000	Q2 - 41	42
S40621000	W - 2	54
	Q2 - 43	42
	Q2 - 46	42

CODE	REF.NO.	Page
S40622000	R - 700-17	44
	Q2 - 44	42
	Q2 - 47	42
S40623000	Q2 - 49	42
S40628000	R - 700-3	44
S40629000	R - 700-12	44
S40635001	Q2 - 40	42
S40640001	Z - 35-5	56
S40641001	Z - 35-11	56
S41013001	Ga - J-53	62
S41060109	A - 709	2
S41202151	S - 700	46
S41205001	K - 504	30
S41206001	K - 505	30
S41222101	G - 25-2	22
	Z - 64	58
	Sp - G-25	60
S41271000	C2 - 91-23	12
S41290201	A - 708	2
S41658000	C2 - 91-1	12
S41660001	C2 - 91-12	12
S41703000	C1 - 12	8
S41705001	C1 - 15	8
S42067001	C1 - 1-1	8
S42069001	C1 - 7	8
S42070001	C1 - 7-1	8
S42083001	C1 - 41	8
S42084101	C1 - 44	8
S42086001	C1 - 44-10	10
S42260000	Q1 - 1-11	36
S42653000	T - 1-15	48
S42658000	Z - 98	58
S42750209	A - 17	2
S42751109	A - 17-1	2
S42752000	A - 17-2	2
S42756101	B1 - 16-7	4
S42827100	F - 24	20
S42839101	D - 710	16
S42840101	D - 713	16
S42849101	D - 726-1	16
S42859001	K - 700	30
S42864101	K - 701	30
S42870201	M - 700	32
S42871201	M - 703	32
S42873101	M - 702	32
S42880001	D - 715	16
S42890001	Z - 91	58
S43175000	Q1 - 1-26-11	36
S43176000	Q1 - 1-26-12	36
S43177000	Q1 - 1-26-1	36
S43178000	P - 1-2	34
S43181000	Q1 - 1-26-13	36
S43184000	Q1 - 1-26-2	36
S43187000	Q1 - 1-26-20	36
S43188000	Q2 - 2-6	42
S43189000	Q1 - 1-26-19	36
S43201000	Q2 - 3-4	42
S43224000	T - 1-9	48
S43225000	T - 1-10	48
S43226000	T - 1-3	48
S43228000	T - 1-13	48
S43236009	T - 2	48
S43237100	T - 1-7	48

CODE	REF.NO.	Page
S43249001	W - 1	54
S43250000	W - 1-1	54
S43251000	W - 1-2	54
S43252000	W - 1-3	54
S43253000	W - 1-4	54
S43254000	W - 1-5	54
S43255000	W - 1-7	54
S43256000	W - 1-8	54
S43257000	W - 1-9	54
S43259001	W - 1-18	54
S43267000	W - 1-14	54
S43268000	W - 1-15	54
S43269000	W - 1-19	54
S43270000	W - 1-16	54
S43271000	W - 1-11	54
S43272000	W - 1-12	54
S43273000	Z - 96	58
S43275000	Q1 - 1-19	36
S43276000	Q1 - 1-20	36
S43277000	Q1 - 1-21	36
S43674000	T - 3	48
S43675000	T - 4	48
S43682100	R - 700-8	44
S43683001	R - 700-6	44
S43686000	R - 700-14	44
S43687001	R - 1-1	44
S43687002	R - 1-2	44
S43688001	R - 1-3	44
S43688002	R - 1-4	44
S43693000	D - 702	16
S43696100	R - 700-15	44
S43900001	M - 705	32
S43901001	M - 708	32
S43902001	M - 711	32
S43903001	M - 718	32
S43904101	M - 723	32
S43907109	A - 707	2
S43909001	M - 715	32
S43981000	W - 1-17	54
S43990001	C3 - 302	14
	Ga - C3-302	61
S43991001	C3 - 302	14
	Ga - C3-302	61
S43992001	C3 - 302	14
	Ga - C3-302	61
S44010001	A - 31	2
S44287000	R - 700-19	44
S44483001	Z - 67-1-1	58
S44485001	Z - 67-1-2	58
S44486101	Z - 67-1-6	58
S44493101	Z - 67-1	58
S44629001	A - 920	2
S44633001	Sp - E-25	59
S44665000	S - 6-1	46
S44665001	S - 6-2	46
S44746100	R - 700-15-1	44
S44748001	R - 700-5	44
S44750100	R - 700-15-2	44
S44940001	C3 - 210-7-2	14
	Ga - C3-210-2	61
S44941001	C3 - 210-7-1	14
	Ga - C3-210-1	61
S44942001	C3 - 100-4	14

CODE	REF.NO.	Page
S44942001	Sp - C3-100	60
S45131001	D - 726-2	16
S45132001	D - 726-3	16
S45133001	D - 726-4	16
S45134001	D - 726-5	16
S45135001	D - 726-6	16
S45147101	B1 - 2	4
S46131001	U2 - 2	52
S46132001	U2 - 2-1	52
S46133001	U2 - 2-1-1	52
S46134001	U2 - 2-1-2	52
S46135001	U2 - 2-1-6	52
S46136000	U2 - 2-1-7	52
S46144100	M - 722	32
S46145000	M - 722-1	32
S46476001	S - 7	46
S46544001	C3 - 200-4-2	14
	Sp - C3-200-2	60
S46545001	C3 - 200-4-1	14
	Sp - C3-200-1	60
S46694000	U1 - 1-3-1-20	50
S47091001	B1 - 16-3	4
S47592000	Q2 - 2-4	40
S47594000	Q2 - 2-7	40
S47595000	Q2 - 2-4-2	40
	Q2 - 2-7-2	40
S47692000	Q1 - 1-7	36
S48578000	P - 1-14	34
S48580000	Z - 103	58
	Q1 - 1-26-17	36
S48587000	S - 1	46
S48589000	S - 2	46
S48666001	N - 1	34
S49071000	Q1 - 1-26-8	36
S49443000	U2 - 3	52
S49464000	S - 18	46
S49465012	S - 21	46
S49466000	S - 503-2	46
S49467001	Q1 - 1	36
S49468001	Q1 - 1-1	36
S49469001	Q1 - 1-2	36
S49470001	Q1 - 1-3	36
S49471000	P - 1-8	34
S49472000	Q1 - 1-26-21	36
S49473000	Q2 - 3-2	40
S49474000	Q2 - 3-2-1	40
S49475000	Q2 - 3-3	40
S49476000	Q2 - 3-3-1	40
S49479001	P - 1	34
S49482000	S - 503	46
S49484000	P - 1-6	34
S49485000	P - 1-7	34
S49486000	P - 1-11	34
S49582001	B1 - 3	4
S49584000	B1 - 12	4
S49586000	Q1 - 1-26-3	36
S49587001	B1 - 16-1	4
S49588001	B1 - 16-2	4
S49589001	B1 - 16-4	4
S49593000	B1 - 19	4
S49602201	Z - 67	58
S49603000	Z - 11	56
S49604000	Z - 20	56

CODE	REF.NO.	Page
S49608001	E - 9	18
S49609001	E - 13	18
S49618000	F - 53	20
S49620000	F - 17	20
S49622000	F - 19	20
S49623000	F - 34	20
S49624000	F - 35	20
S49625000	F - 36	20
S49626000	E - 14-10	18
S49627001	G - 3	22
S49629101	J - 1	26
S49644001	J - 16	26
S49645001	J - 10	26
S49646001	J - 22	26
S49647001	J - 22-1	26
S49648001	J - 26	26
S49649001	J - 26-1	26
S49650001	J - 29	26
S49651001	J - 35	26
S49653001	M - 5	32
S49654001	M - 5-1	32
S49655001	M - 5-4	32
S49656001	M - 6	32
S49657001	M - 7	32
S49660001	L - 3	30
S49661001	L - 7	30
S49663001	L - 13	30
S49664000	L - 20	30
S49669100	U1 - 1-3-1-1	50
S49672001	U1 - 1-3-1-2	50
S49673000	U1 - 1-3-1-11	50
S49674001	U1 - 1-3-1-12	50
S49685000	E - 14-11	18
S49689001	B1 - 16-6	4
S49938000	Q1 - 1-25	36
S49939001	Q1 - 1-26	36
S49955001	C3 - 905-2	14
S49957000	F - 18	20
	F - 46	20
S49958000	F - 47	20
S49959001	F - 14	20
S49980001	Ga - J-53	62
	Sp - J-53	59
S49981000	E - 14-9	18
S49982000	F - 12	20
S49983000	F - 20	20
S49984000	F - 21	20
S49985000	F - 48	20
S49986000	F - 49	20
S49987000	F - 50	20
S49988001	J - 45	26
S49992000	F - 1	20
S49994001	J - 38	26
S49995001	F - 51	20
S50645000	P - 1-10	34
S51098000	A - 40	2
S51099000	C1 - 17	8
S51100001	C1 - 18	8
S51101001	C1 - 21	8
S51102001	C2 - 903	12
S51103001	C1 - 25	8
S51282001	Z - 35-3	56
S51283001	Z - 35-1	56

CODE	REF.NO.	Page
S51449001	Ga - J-53	62
S51451000	U1 - 1-3-1-10	50
S51459001	A - 404	2
S51460009	A - 33	2
S51461001	A - 402	2
S51462001	C1 - 30	8
S51463001	C1 - 31	8
S51465001	C1 - 37	8
S51801001	T - 1-2	48
S51846101	U1 - 1-3	50
S51847101	U1 - 1-3-1	50
S51854209	R - 700	44
S51856001	C1 - 39	8
S51857001	C1 - 1	8
S51858001	C1 - 1-2	8
S51859101	G - 5	22
S51860001	C1 - 47-3	10
S52100001	C3 - 905-1	14
S52582001	W - 50	54
S52834201	B2 - 30	6
S52836000	B2 - 47	6
S52838000	B2 - 35	6
S52839100	B2 - 36	6
S52840001	B2 - 40	6
S53032000	Q1 - 11	36
S53055100	V - 2	54
S53091001	C2 - 91	12
S53092001	C2 - 91-2	12
S53094001	C2 - 91-16	12
S53095000	C2 - 91-17	12
S53096001	C2 - 91-21	12
S53097001	G - 1	22
S53099001	C1 - 13	8
S53100001	C1 - 19	8
S53108001	C1 - 33	8
S53109001	C1 - 36	8
S53118001	R - 3-1	44
S53118002	R - 3-2	44
S53119001	A - 13-1	2
S53120001	A - 13-2	2
S53136000	S - 6	46
S53182101	A - 41	2
S53207001	E - 8	18
S54145001	A - 703	2
S54650000	U1 - 1-3-1-7	50
S54691000	U1 - 1-3-1-7-1	50
S54984001	C3 - 905	14
	Ga - C3-905	61
S55103001	B1 - 1	4
S55104001	B1 - 4	4
S55105001	B1 - 16	4
S55107001	D - 700	16
S55108001	M - 1	32
S55109001	M - 1-1	32
S55111001	L - 17	30
S55134001	M - 704	32
S55140001	E - 29	18
S55181001	L - 1	30
S55199001	M - 22	32
S55208000	A - 25	2
S55214000	E - 28	18
S55215001	E - 19	18
S55216001	E - 14-1	18

CODE	REF.NO.	Page
S55311001	Z -75-1	58
S55311002	Z -75-2	58
S55402000	T -1-4	48
S55404000	Q1 -10	36
S55405001	T -1	48
S55414001	Q1 -H-1	38
S55415001	Q1 -H-2	38
S55416001	Q1 -H-3	38
S55417001	Q1 -H-4	38
S55418001	Q1 -H-5	38
S55419001	Q1 -H-6	38
S55420001	Q1 -H-7	38
S55421001	Q1 -H-8	38
S55422001	Q1 -H-9	38
S55432000	S -703	46
S55433000	S -704	46
S55473000	Q1 -1-26-4	36
S55572001	B2 -31	6
	B2 -48	6
S55627001	Q1 -54	38
S55629001	S -40	46
S55630001	S -40-1	46
S55632001	S -40-3	46
S55633001	Z -70	58
S55658000	E -27	18
S55659000	F -54	20
S55663001	Z -23	56
S55927001	E -14	18
S56017000	B2 -30-1	6
S56018000	B2 -30-2	6
S56019001	B2 -30-3	6
S56522000	T -1-1	48
S57925001	A -23	2
UA4817000	Q1 -10-1	36
UD2390001	U2 -2-1-8	52
U32744000	P -1-12	34
U34870001	T -1-2-3	48
Y51030150	P -1-15	34
0A4300605	T -1-6	48
	T -1-11	48
0A4301005	P -1-13	34
	Q1 -1-26-18	36
0A4400605	Q2 -42	42
0A5400805	T -1-5	48
0A5400806	R -700-20	44
	S -17	46
	S -31	46
	S -33	46
	S -35	46
	Q1 -1-9	36
0A5401006	S -5	46
	S -11	46
	S -41	46
	S -43	46
0A5401206	Q1 -1-5	36
	Q1 -1-10	36
0A5401606	Q2 -50	42
0A5403006	Q1 -1-8	36
0B1351606	Z -93	58
002300603	T -1-14	48
004400603	U1 -1-3-1-5	50
008400604	K -515	30
	T -1-17	48

CODE	REF.NO.	Page
008400604	Q1 -1-22	36
013679412	H -1-7	24
014680622	E -3	18
	H -1-9	24
	J -8-2	26
	C2 -91-6-2	12
014710522	K -14	30
014760622	E -7	18
	E -10	18
	E -15	18
	J -33	26
	Z -10	56
	C1 -1-7	8
	C1 -6	8
	C1 -7-4	8
	C1 -11	8
	C1 -14	8
	C1 -20	8
	C1 -26	8
	C1 -29	8
	C1 -44-11	10
	C2 -91-9	12
014760632	G -28	22
014770622	E -13-1	18
	J -2	26
	J -23	26
	B1 -14	4
014770632	D -701	16
014780622	B1 -5	4
	B1 -17	4
017082206	U2 -2-4-5	52
017680512	A -15	2
	B2 -49	6
017751412	D -709	16
018061022	B2 -41	6
018061436	Q2 -4	42
018062522	B2 -42	6
018063022	B2 -44	6
018081636	T -7	48
018082536	U1 -1-3-4	50
018083022	B2 -37	6
018400622	C2 -91-11	12
018400632	C1 -34	8
018401236	B2 -30-4	6
	U1 -1-3-10	50
018402522	S -3-2	46
018405032	Z -920	58
018501022	C2 -50	12
018501036	U1 -1-3-7	50
018501422	E -20	18
018680522	C1 -53	10
018681022	J -12	26
	K -709	30
	M -712	32
021060102	B2 -43	6
021060106	Z -56	58
	Q2 -6	42
021300206	U2 -2-1-10	52
021400102	Z -921	58
021400106	S -40-10	46
	Q2 -52	42
021400206	Q1 -1-6	36
021500106	R -21	44

CODE	REF.NO.	Page
021500106	T -9	48
	Z -35-8-3	56
	Z -35-11-1	56
021660102	K -705	30
	Z -67-1-4	58
021670102	L -10	30
021670202	K -503	30
021680202	H -1-24	24
021750102	D -707	16
025030232	R -700-11	44
025030236	U2 -2-1-9	52
025040232	C1 -35	8
	C2 -91-10	12
025040236	Q2 -51	42
	U1 -1-3-1-16	50
	U1 -1-3-12	50
025050236	T -6	48
	U1 -1-3-9	50
025060232	A -406	2
	B2 -46	6
	C2 -48	12
025060236	Q2 -5	42
025060336	Z -57	58
025080132	A -35	2
025080232	B2 -39	6
025080236	U1 -1-3-6	50
	U2 -2-1-4	52
	U2 -2-4-8	52
025350236	A -702	2
025350332	L -16	30
025680132	N -7	34
025680232	F -8	20
	H -1-27	24
	H -4	24
	C1 -54	10
025750132	M -706	32
025770232	E -32	18
026030232	Z -67-1-5	58
026040236	S -40-8	46
026050136	Z -35-11-5	58
028030242	R -700-10	44
028040246	B2 -30-5	6
	U1 -1-3-11	50
028050246	Z -35-8-2	56
	U1 -1-3-8	50
028060242	B2 -45	6
028060246	Q2 -7	42
028080240	U2 -2-4-7	52
028080242	B2 -38	6
028080246	U1 -1-3-5	50
028350242	J -22-6	26
	L -15	30
	M -5-6	32
028680242	F -9	20
	M -713	32
032422003	R -22	44
	Z -71	58
	Z -92	58
032461606	Z -58	58
037200615	W -1-10	54
037300615	W -1-13	54
037300816	T -1-12	48
037301015	W -1-6	54

CODE	REF.NO.	Page
037301215	Z - 4-3	56
047401442	L - 6	30
048040342	D - 725	16
	L - 19	30
	M - 15	32
	M - 707	32
	C2 - 91-20	12
048050342	H - 1-10	24
	C2 - 91-8	12
048050346	U1 - 1-3-1-14	50
048060342	J - 32	26
048070342	E - 18	18
	J - 19	26
048100142	H - 1-4	24
048150142	B1 - 9	4
048180142	C1 - 9	8
052400606	U1 - 1-3-1-15	50
052400806	U2 - 2-1-11	52
052501205	R - 20	44
060670512	F - 16	20
060670612	A - 706	2
	G - 4	22
	G - 6	22
060680712	A - 408	2
	C1 - 32	8
060681212	J - 5	26
	M - 725	32
061660806	Z - 67-1-3	58
062020806	S - 40-4	46
062300612	S - 502	46
	S - 701	46
062300806	S - 8	46
062301205	U1 - 1-3-1-8	50
062302506	R - 700-9	44
	U1 - 1-3-1-21	50
062400616	S - 40-6	46
062400806	N - 2	34
062401006	Z - 76	58
062401216	S - 40-7	46
062501406	Z - 35-11-2	58
	Z - 35-11-4	58
062503506	Z - 35-11-3	58
062660412	E - 14-3	18
062660712	E - 14-7	18
062670412	G - 31	22
062670512	F - 28	20
	F - 39	20
	F - 52	20
	S - 13	46
	Z - 67-1-7	58
062670612	F - 704	20
	G - 24	22
	L - 21	30
	C1 - 55	10
062671012	L - 14	30
062671016	Z - 67-2	58
062680512	H - 1-18	24
	K - 707	30
	K - 711	30
062680612	F - 7	20
	F - 31	20
	H - 3	24
	C1 - 38	8

CODE	REF.NO.	Page
062680712	B1 - 16-8	4
062680812	M - 9	32
062681012	A - 26	2
	C1 - 24	8
062681212	D - 722	16
	H - 2	24
062681412	N - 6	34
062710612	G - 2	22
062710812	A - 710	2
	A - 711	2
	L - 2	30
062711012	A - 18	2
	A - 42	2
062761012	A - 405	2
062771012	M - 701	32
070688850	C1 - 16	8
	C1 - 22	8
071047650	C1 - 5	8
072630260	B1 - 7	4
081003670	E - 12	18
	E - 17	18
091170009	P - 1-5	34
093650008	P - 1-3	34
093650032	P - 1-4	34
100022004	H - 1-26	24
100022005	J - 25	26
	J - 26-3	26
	M - 1-3	32
	M - 4	32
	M - 710	32
100032004	J - 51	28
	C1 - 43	8
100090004	E - 2	18
100136001	G - 20	22
	H - 1-20	24
100242003	B1 - 20	4
100250001	B1 - 13	4
100360003	J - 54	28
100402004	G - 17	22
100645003	A - 34	2
	K - 511	30
	M - 714	32
100659001	K - 704	30
100666002	U2 - 2-2	52
100887001	Z - 30	56
101268002	U2 - 2-1-5	52
101572101	Z - 28	56
101706001	E - 6-1	18
	C1 - 3-2	8
102630001	B1 - 18	4
103810002	E - 31	18
104449001	A - 11	2
	A - 712	2
	A - 713	2
104450101	A - 4	2
	A - 10	2
	A - 400	2
104525001	Sp - G-14	59
104567001	F - 22	20
	F - 702	20
105812003	J - 15	26
106129001	J - 22-5	26
106129002	M - 5-5	32

CODE	REF.NO.	Page
106147002	M - 717	32
106629002	A - 14	2
	A - 403	2
107017001	T - 1-20	48
107017002	A - 705	2
107038003	C2 - 91-15	12
107149001	F - 5	20
	F - 13	20
107321003	A - 704	2
	L - 4	30
107321009	T - 1-19	48
107415014	Sp - B-26	60
107415414	Sp - Z-17	60
107453001	D - 706	16
107606001	Sp - G-14	59
107779001	Z - 29	56
107780001	Z - 31	56
108802001	F - 701	20
	C1 - 1-4	8
109239002	A - 24	2
109714000	Z - 5	56
	Z - 12	56
	Z - 21	56
109763002	M - 16	32
110161004	J - 37	26
	M - 721	32
110168001	C2 - 91-22	12
110233001	J - 36	26
110251001	L - 9	30
110367001	J - 31	26
111140002	J - 50	28
114294001	G - 9	22
114483002	Z - 22	56
114486002	Z - 6	56
115186001	G - 19	22
115188001	G - 21	22
116694001	U2 - 2-4-6	52
116920001	B1 - 8	4
116922001	G - 12	22
117934001	A - 6	2
	A - 17-3	2
117936001	A - 700	2
	U1 - 1-3-1-17	50
118064001	Z - 34	56
118837001	Z - 27	56
119707003	U2 - 2-4-3	52
119708001	U2 - 2-4-4	52
120448001	H - 1-13	24
120990001	H - 1-14	24
121007001	J - 42	26
122991001	Z - 14	56
123006001	B1 - 15	4
123882001	E - 30	18
133188001	U2 - 2-4-2	52
133740006	Z - 55	58
139096001	C2 - 91-6-1	12
140392009	A - 7	2
	A - 401	2
140647101	F - 703	20
	S - 40-5	46
140726000	B1 - 6	4
141492001	J - 26-2	26
	M - 1-2	32

CODE	REF.NO.	Page
141590001	H - 1-25	24
141786001	E - 1	18
142443001	Z - 26	56
142656001	U2 - 2-5	52
142721001	Z - 33	56
142990001	Z - 35-10-3	56
143591001	C2 - 91-7	12
143882001	Z - 9	56
144105000	H - 1-23	24
144110001	H - 1-21	24
144226001	Z - 51	58
144458001	B1 - 23	4
144588001	Sp - G-10	59
144712001	B1 - 2-1	4
145318001	C1 - 40	8
	C1 - 42	8
145446001	G - 16	22
	G - 22	22
	H - 1-22	24
145465001	B1 - 16-5	4
145472001	D - 716	16
145478101	M - 2	32
145519001	Sp - G-10	59
145547001	F - 27	20
145646025	Sp - B-26	60
145646425	Sp - Z-17	60
146255000	Z - 53	58
146256001	Z - 52	58
147777000	B1 - 16-9	4
148133001	C1 - 44-4	10
148196000	D - 711	16
148197000	D - 712	16
148738000	F - 4	20
	F - 40	20
	F - 41	20
148764001	M - 719	32
148813001	J - 22-4	26
148847001	J - 13	26
	R - 23	44
148904001	U2 - 2-1-3	52
149173001	Z - 25	56
149287000	S - 30	46
149796001	R - 10	44
149809000	R - 700-18	44
	T - 1-16	48
	W - 3	54
	Q2 - 45	42
	Q2 - 48	42
150173003	Z - 35-7	56
150174000	Z - 35-4-3	56
	Z - 35-5-1	56
150179002	Z - 35-8-1	56
150182000	Z - 35-2	56
150183000	Z - 35-10-2	56
150206002	Z - 35-4-1	56
150460001	D - 704	16
150461001	D - 705	16
151907001	M - 709	32
152242001	B1 - 24	4
152243001	B1 - 25	4
152245101	E - 4	18
152678201	E - 11	18
	E - 16	18

CODE	REF.NO.	Page
152682101	Sp - E-21	59
152683101	E - 14-4	18
152684101	E - 14-5	18
152685903	Sp - E-22	59
152686101	Sp - E-21	59
152687902	Sp - E-22	59
152690401	Sp - E-24	59
152756001	C1 - 10	8
152760051	C1 - 8	8
152842059	A - 22	2
152872001	G - 8	22
152881001	G - 27	22
152883000	G - 29	22
152884001	G - 30	22
152889001	G - 23	22
152891101	G - 26	22
152948001	F - 33	20
152956001	F - 42	20
152969001	F - 38	20
152973001	C1 - 7-5	8
153242000	Z - 102	58
	Q1 - 1-26-15	36
153369001	C2 - 91-13	12
153370001	C2 - 91-14	12
153377001	C1 - 44-2	10
153378001	C1 - 44-3	10
153380001	C1 - 44-9	10
153383001	C1 - 45	10
153384001	C1 - 46	10
153391001	C1 - 47-1	10
153392001	C1 - 47-2	10
153393001	C1 - 4	8
153493001	C3 - 210-1-2	14
	Ga - C3-210-2	61
153498001	C3 - 210-1-1	14
	Ga - C3-210-1	61
153503001	C3 - 110-1	14
	Ga - C3-110	61
153596001	J - 20	26
153597001	J - 22-2	26
	M - 5-2	32
153924001	F - 45	20
	C1 - 1-3	8
154339101	Sp - E-24-1	59
154340101	Sp - E-24-1	59
154341001	Sp - E-24-2	59
	Sp - E-24-2	59
154342001	Sp - E-24-3	59
154467001	Z - 4-2	56
154514001	S - 40-9	46
154528001	H - 1-12	24
154596000	J - 21	26
154599000	J - 6	26
154663001	Sp - E-25	59
155055001	S - 3-1	46
155167002	D - 714	16
155559001	L - 18	30
155578000	B1 - 21	4
156076101	C1 - 44-1	8
156077001	C1 - 44-7	10
156080000	C1 - 44-8	10
156082001	C3 - 210-5-2	14
	Ga - C3-210-2	61

CODE	REF.NO.	Page
156083001	C3 - 210-5-1	14
	Ga - C3-210-1	61
156084001	C3 - 110-5	14
	Ga - C3-110	61
156085001	C3 - 210-4-2	14
	Ga - C3-210-2	61
156086001	C3 - 210-4-1	14
	Ga - C3-210-1	61
156087001	C3 - 110-4	14
	Ga - C3-110	61
156088001	C3 - 210-6-2	14
	Ga - C3-210-2	61
156089001	C3 - 210-6-1	14
	Ga - C3-210-1	61
156090001	C3 - 110-6	14
	Ga - C3-110	61
156108001	C1 - 44-5	10
156109001	C1 - 44-6	10
156112003	Z - 35-6	56
156206001	K - 15	30
157968001	H - 1-17	24
159111001	K - 706	30
159565000	F - 23	20
159574101	H - 1-19	24
159610301	Sp - E-24	59
159612001	Sp - E-24-3	59
159613051	Sp - E-25	59
159805001	G - 15	22
159905001	J - 14	26
	M - 716	32
181995001	E - 6	18
183493001	C1 - 3	8
200190001	U2 - 2-3	52
218859001	S - 25	46
	Q2 - 2-1-5	40
	Q2 - 2-2-5	40
	Q2 - 2-3-5	40
	Q2 - 2-4-5	40
	Q2 - 2-7-5	40
224514001	Q2 - 2-1-4	40
	Q2 - 2-2-4	40
	Q2 - 2-3-4	40
	Q2 - 2-4-4	40
	Q2 - 2-7-4	40
228475000	F - 44	20
	J - 55	28
	R - 13	44
	R - 25	44
	S - 22	46
	S - 702	46
	Q1 - 12	36
	U1 - 1-3-1-9	50
231071001	J - 17	26
232384001	Q1 - 1-26-7	36
402887001	E - 14-6	18
417382001	T - 1-2-5	48
552907000	S - 4	46
	S - 10	46
	S - 42	46
623033000	D - 703	16
625010000	S - 12	46

brother®

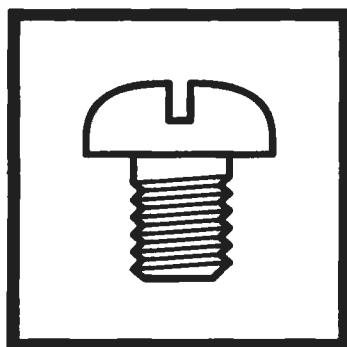

パーツブック
PARTS BOOK

ブラザー工業株式会社

〒467-8561 名古屋市瑞穂区苗代町15番1号 TEL(052)824-2392

BROTHER INDUSTRIES, LTD.

15-1, Naeshiro-cho, Mizuho-ku, Nagoya 467-8561, Japan. Phone: 81-52-824-2177

Printed in Japan

118-P34
S96P34-001
2001.08. H (1)

From the library of: Superior Sewing Machine & Supply LLC